

MARINE ENVIRONMENT PROTECTION
COMMITTEE
81st session
Agenda item 7

MEPC 81/INF.5
15 December 2023
ENGLISH ONLY

Pre-session public release: ☒

REDUCTION OF GHG EMISSIONS FROM SHIPS

Commercial Readiness of Absolute Zero GHG Technologies

ZESTAs

SUMMARY

Executive summary: This document presents in detail the commercial and technical readiness of absolute zero GHG technologies which have been built and validated in a marine operational environment. Several case studies are provided. A number of such technologies are operational on a commercial basis, including on absolute zero GHG ships. The technology required for absolute zero GHG maritime supply chains is in early adoption. Definition of standards is ongoing for some technologies and crew training has been established for each to varying degrees. Absolute zero GHG vessels of greater sizes and power can be achieved by combining different commercialised technologies.

Strategic direction, if applicable: 3: Respond to climate change

Output: 3.4 Promotion of technical cooperation and transfer of technology relating to the reduction of GHG emissions from ships

Action to be taken: Paragraph 18

Introduction to Absolute Zero GHG Technology

1 MEPC 80 approved and adopted the IMO Revised GHG Strategy (resolution MEPC.377(80), which enhanced common ambition to reach net-zero GHG emissions from international shipping by or around, i.e. close to, 2050, a commitment to ensure an uptake of zero or near-zero GHG emission technologies, fuels and/or energy sources to represent at least 5%, striving for 10%, of the energy used by international shipping by 2030, and to reduce the total annual GHG emissions from international shipping by at least 20%, striving for 30%, by 2030 and by at least 70%, striving for 80% by 2040, compared to 2008.

2 ISWG-GHG 13/3/9 defined the term ‘absolute zero’ as an energy source that produces “no emissions of carbon dioxide (CO₂) or other greenhouse gases (GHG) across all scopes, i.e., where there are no direct emissions from fuel consumption or indirect emissions from energy purchased or any GHG emissions from production to end use.” As MEPC 78/7 and ISWG-GHG 12/3 discussed, renewable energy is the production source of ‘absolute-zero’-GHG marine fuels.

3 This document presents the paper by ZESTAs, Commercial Readiness of Absolute Zero GHG Technologies (December 2023 Edition), found in the Annex.

4 The MARIN NL Model for ESSF SAPS (cited in ISWG-GHG 13/3/9) compares a multitude of potential and conventional marine fuels GHG emissions WTW over a 100-year Global Warming Potential (GWP) and finds that a number indeed produce 0% GHG emissions WTW over a 100-year GWP. These absolute zero-GHG fuels will be considered in the paper.

5 References are made to Technology Readiness Levels (TRLs) and Commercial Readiness Levels (CRLs) throughout the paper (Table 1). These follow the expanded definitions as presented to ISWG-GHG 14 on 22nd March 2023 by IMO Secretariat, DNV and Ricardo plc: “Update On The Imo Future Fuels & Technology Project (Fft Project)”.

Table 1: Technology readiness levels (TRLs) extended to accommodate commercial readiness levels (CRLs). Adapted from presentation to ISWG-GHG 14 on 22nd March 2023 by IMO Secretariat, DNV and Ricardo plc.

Maturity	Rating	Description of readiness level
Basic research	TRL1	Basic principles of scientific research observed and reported
	TRL2	Invention and research of practical application
	TRL3	Proof of concept with analytical and experimental studies to validate the critical principles of individual elements of the technology
Development	TRL4	Development and validation of component in a laboratory
	TRL5	Pilot scale testing of components in a simulated environment to demonstrate specific aspects of the design
	TRL6	Prototype system built and tested in a simulated environment
Demonstration	TRL7	Prototype system built and validated in a marine operational environment
	TRL8	Active commissioning where the actual system is proven to work in its final form under expected marine operating conditions
Deployment: early adoption	TRL/CRL9	Operational application of system on a commercial basis – technically ready but limited number of vessels/first-of-a-kind facilities
	CRL10	Integration needed at scale: solution is commercial but needs further integration efforts to achieve full potential – may be 100’s or a few 1000 vessels or a small number of at-scale facilities, small share of market
Mature	CRL11	Proof of stability reached, with predictable growth

6 Only technologies which have reached at least demonstration, i.e. built and validated in a marine operational environment (TRL7 or higher), are considered.

Results

7 Electric systems of various types are commercially ready. Pure electric systems produce absolute zero greenhouse gases and are at CRL10 on certain ship types, most notably RoPax ferries up to about 11,000 GT, but also demonstrated on tugs up to 70 BP, a bunker ship and a 120 TEU container ship. Hybrid-electric vessels have seen the largest diffusion of battery Energy Storage Systems (ESS) and highest commercial readiness (CRL11), including combinations of both conventional diesel- or LNG-hybrid systems and hybrid hydrogen-electric systems (see Figure 1). Plug-in hybrid ESS are commercialised at CRL10 but, like pure electric vessels, are limited by fixed charging infrastructure.

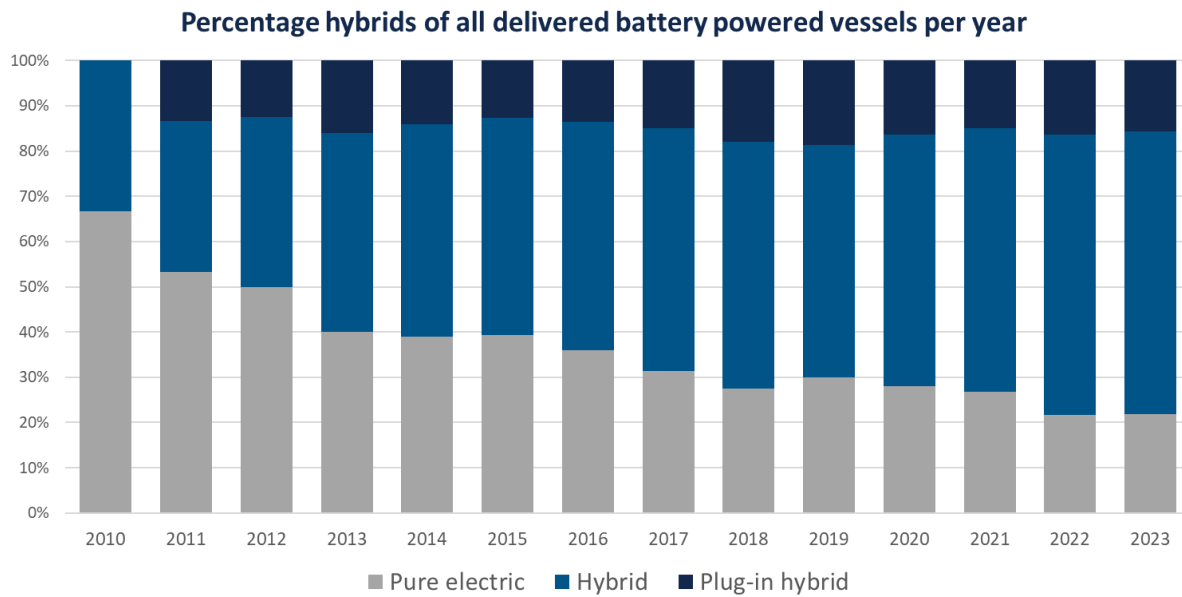

Figure 1: Percentage system types of vessels delivered by year (Maritime Battery Forum, December 2023)

8 Fixed charging infrastructure has developed up to CRL10 to meet requirements of pure electric and plug-in hybrid-electric vessels (see Figure 2). Swappable batteries enable recharging where fixed charging points cannot meet operational requirements. Swappable batteries are at TRL/CRL9. Renewable electricity for charging has been ensured in some cases using purchase agreements or by using on-site renewables. For the offshore sector, charging at an offshore wind farm has been demonstrated in harbour trials by two different technology providers (TRL7) (see Figure 3). One provider aims to commission and validate in early 2024, taking offshore charging to TRL8, and commercially deploy a 1.5 MW unit end of 2024 (TRL/CRL9).



Figure 2: Shoreside fixed 10.5 MW charging connection for Aurora of Helsingborg and Tycho Brahe passenger ferries.



Figure 3: Harbour trials of offshore charging systems. Left: 1.5 MW charging point to be fixed on an offshore structure (image: MJR Power & Automation). Right: floating buoy charging point (image: Jebb Smith Ltd)

Hydrogen fuel cells have reached commercialisation (TRL/CRL9). Currently, the largest installed fuel cell system is 0.825 MW capacity on the inland container vessel H2 Barge 1. A 1.2 MW system is currently being retrofitted on another inland container vessel, FPS Waal. the largest systems at Final Investment Decision stage are for two 6.5 MW fuel cell systems, expected to be installed before October 2025 for main propulsion on RoPax ferries of about 5,000 GT each (see Figure 4). Fuel cell systems providing auxiliary power exist on much larger vessels. Approval processes have been challenging but are shown to be simplifying with increasing experience, for example: class approval of a hydrogen system in the inland sector awarded in 2023 took 4 years but only 6 months for the following project.

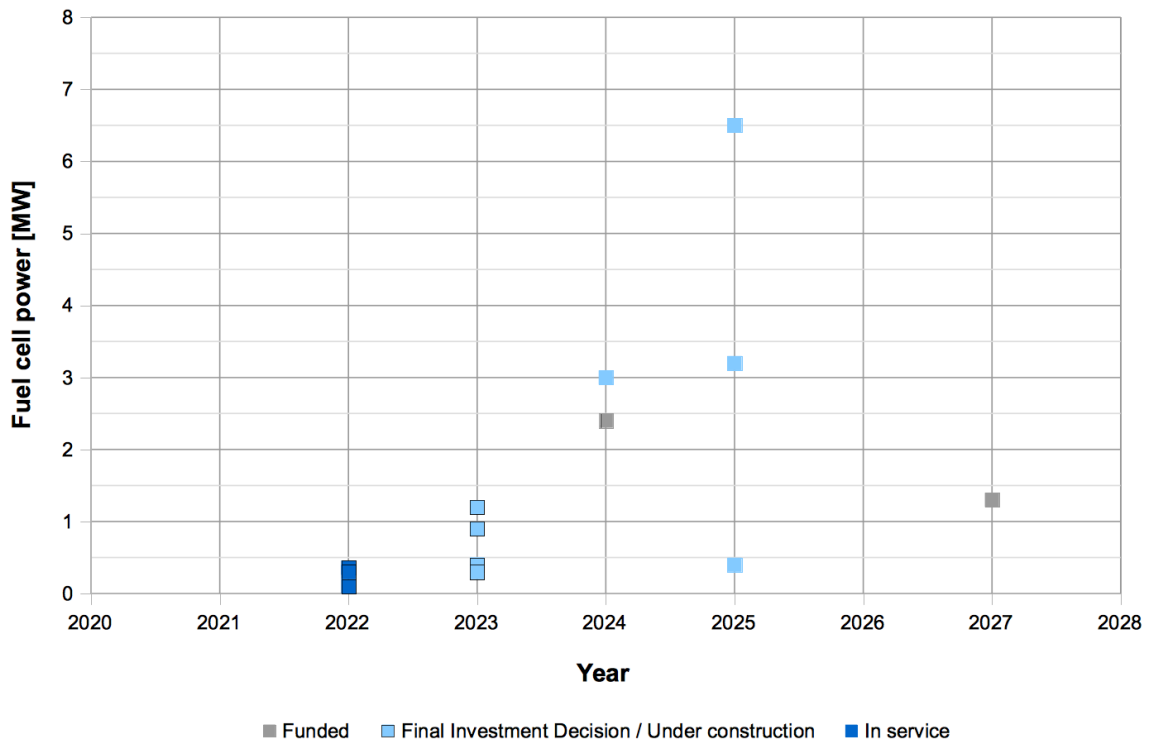

Figure 4: Installed fuel cell system nominal power outputs for existing and expected vessels.

10 Onboard storage of hydrogen in various forms is commercialised: liquid hydrogen, compressed gaseous hydrogen and metal hydride are all TRL/CRL9. Liquid hydrogen is stored in vacuum-insulated cryogenic tanks at -253°C. Compressed hydrogen is stored in cylindrical tanks at up to 700 bar pressure. Storage capacity on existing ships is larger for liquid hydrogen (up to 4,000 kg on MF Hydra) than compressed hydrogen (up to 1,000 kg at 300 bar on H2 Barge 1).

11 Bunkering of hydrogen fuel in various forms is available in a number of locations around the world (see Figure 5). Liquid hydrogen bunkering using mobile systems have been developed to overcome bottlenecks in large-scale liquid hydrogen supply and are TRL/CRL9 (see Figure 6). Fixed systems are TRL8, having demonstrated shore-to-ship transfer at liquid hydrogen terminals in Japan and Australia. Compressed hydrogen bunkering is commercialised at various pressures (TRL/CRL9). Rates of fuel transfer are higher for liquid hydrogen (up to 3,000 kg/hour) than compressed (up to 220 kg/hour). Swapping of compressed hydrogen tanks for rapid refuelling is at TRL/CRL9.

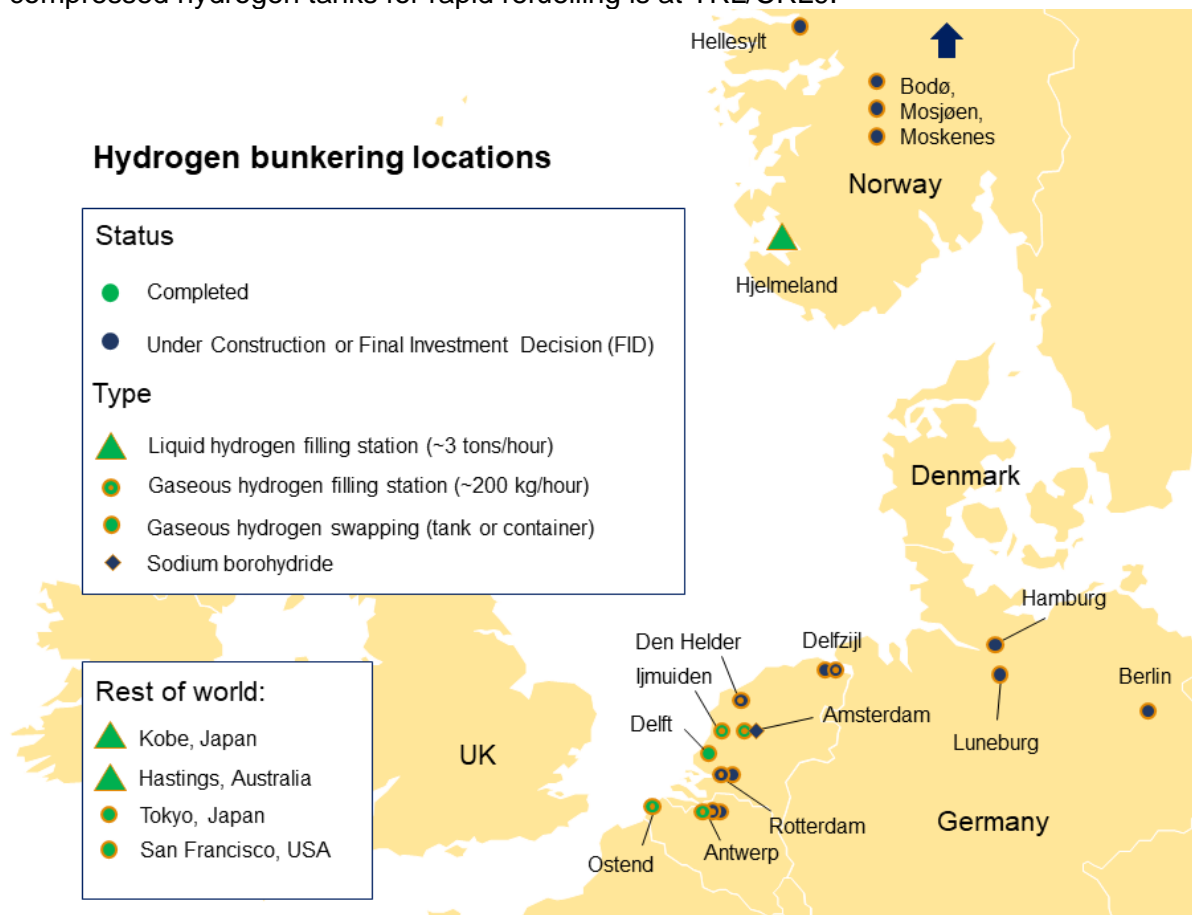

Figure 5: Map of hydrogen bunkering locations globally in December 2023.



Figure 6: Mobile liquid hydrogen bunkering tower designed and owned by Norled attached to a tube trailer, bunkering the Hydra passenger ferry. (Credit: Norled)

12 Technology to produce 'green' (absolute zero GHG) hydrogen fuel is in early adoption. Electrolysers are CRL10 with an estimated 2.9 GW of capacity operational at the end of 2023, corresponding to about 423,000 tonnes/year and an almost fivefold increase in capacity compared to 2022. The majority of installed capacity is located in China. By the end of 2023, manufacturing capacity was estimated at 13.9 GW/year, located primarily in China, Europe, India and North America. Offshore green hydrogen production using wind power was demonstrated in 2023 and is at TRL/CRL9.

13 Technologies required for a maritime hydrogen fuel supply chain are deployed and in early adoption. Large-scale onshore hydrogen storage is at TRL/CRL9, either as liquid in tanks or compressed in underground salt caverns. The largest operational liquid hydrogen tank has 336 tonnes capacity while the largest operational salt cavern has up to 1.5 million tonnes capacity (at 150 bar). Hydrogen liquefaction is at CRL10 with facilities able to deliver up to 90 tonnes/day. A 178-tonne liquid hydrogen tank is installed for the purpose of shore-to-ship transfer at an import terminal in Kobe, Japan. Transport of compressed hydrogen using pipelines is an established technology (CRL11), while carriage by sea is at TRL/CRL9 (liquid, up to 90 tonnes) and by road is at CRL10, both for liquid and compressed.

14 Wind propulsion technology is presented in detail in MEPC80/INF.33 and is at TRL/CRL9 for rotor sails, suction wings, rigid sails, kites and soft/hybrid sails. Rotor sails, rigid sails and kites are expected to reach CRL10 by 2025 at the latest.

15 Combinations of absolute zero GHG technologies facilitate absolute zero GHG vessels. Electric systems are the foundation of absolute zero GHG vessels. By integrating electric systems with hydrogen fuel cells, wind propulsion and supplementary technologies for increased energy efficiency or onboard renewable energy generation, absolute zero GHG vessels of greater sizes and power can be achieved using demonstrated and commercialised technology.

16 Crew training courses for electric systems are well-established in International Convention on Standards of Training, Certification and Watchkeeping for Seafarers (STCW) competencies but some aspects are not fully covered such as advanced battery safety and management. Crew training for hydrogen fuel is technically incorporated in the IGF Code training structure but lacks the scope to address specifics of hydrogen systems. A flag state-recognised hydrogen crew training course has been developed in the UK as a follow-on from LNG/IGF training. Wind propulsion lacks a clear crew training structure for commercial operations but courses are offered by universities.

17 Case studies are referenced throughout the paper and are found in the Appendix. These offer additional details and specification data on example technologies and vessels.

Table 2: List of all TRLs and CRLs of the technologies presented in the following paper.

Technology	TRL/CRL
Electric systems	
Battery Energy Storage Systems (ESS) on pure electric vessels	CRL10, up to ~11,000 GT
Battery Energy Storage Systems (ESS) on plug-in hybrid vessels	CRL10, all vessel sizes
Battery Energy Storage Systems (ESS) on hybrid-electric vessels	CRL11, all vessel sizes
Onshore fixed charging systems	CRL10
Offshore fixed charging systems	TRL7 (expected TRL8 by January 2024)
Swappable battery recharging	TRL/CRL9 to CRL10
Electric propulsion motors	CRL11, up to 41 MW (up to 80 MW on naval vessels)
Electric pod thrusters	CRL11, up to 22 MW
Electric drives	CRL11, up to 30 MW/motor or 50 MW/system
Hydrogen propulsion	
Low temperature PEM fuel cell systems for main propulsion power	TRL/CRL9 on vessels up to 2700 GT
Low temperature PEM fuel cell systems for auxiliary power	TRL/CRL9
Liquid hydrogen onboard storage	TRL/CRL9, up to 4000 kg with zero BOG
Compressed hydrogen onboard storage	TRL/CRL9, up to 1000 kg, at 300 to 700 bar
Metal hydride storage	TRL/CRL9
Liquid hydrogen ship-to-shore direct filling (mobile)	TRL/CRL9, up to 3,000 kg/hour
Liquid hydrogen ship-to-shore direct filling (fixed)	TRL/CRL9

Compressed hydrogen ship-to-shore direct filling (fixed)	TRL/CRL9, up to 220 kg/hour
compressed hydrogen tank/container swapping	TRL/CRL9
Metal hydride bunkering	TRL8
Green hydrogen production and infrastructure	
<i>Green hydrogen production</i>	
Alkaline electrolysers (AE)	CRL10
Proton Exchange Membrane (PEM) electrolysers	CRL10
Offshore green hydrogen production using wind power	TRL/CRL9 up to 1 MW
Offshore green hydrogen production using wave power	Expected TRL/CRL9 in 2024
<i>Large-scale storage</i>	
Liquid hydrogen tanks	TRL/CRL9 up to 336 tonnes, CRL10 at smaller capacities
Liquefaction	CRL10, up to 90 tonnes/day
Compressed gaseous salt cavern storage	TRL/CRL9, up to 1.5 million tonnes
<i>Transport</i>	
Pipelines (compressed hydrogen)	CRL11
Liquid hydrogen carriage by sea	TRL/CRL9, up to 90 tons
Road transport (liquid hydrogen)	CRL10
Road transport (compressed hydrogen)	CRL10
Liquid hydrogen terminal	TRL/CRL9
Wind propulsion	
Rotor sails	TRL/CRL9
Suction wings	TRL/CRL9
Rigid sails	TRL/CRL9
Kites	TRL/CRL9
Soft/hybrid sails	TRL/CRL9
Energy efficiency technologies	
Air lubrication	CRL10
Hull Vane	TRL/CRL9
Bow wind deflector	TRL/CRL9

Gate rudder system	TRL/CRL9
Onboard renewable generation technologies	
Bow foils	TRL/CRL9
Onboard solar panels	TRL/CRL9

Action requested of the Committee

18 The Committee is invited to note the information presented, especially the Technology Readiness Levels (TRLs) and Commercial Readiness Levels (CRLs) of the absolute zero GHG technologies, in the development of the mid-term measures.

Commercial Readiness of Absolute Zero GHG Technologies

December 2023 Edition



Zero Emissions Ship
Technology Association

15 December 2023

Table of Contents

List of Figures.....	2
List of Tables.....	3
Abbreviations and Definitions	4
1.0 Electric Systems.....	5
1.1 Marinized Batteries	5
1.1.1 Types of electric systems	7
1.1.1.1 Pure electric: only batteries as energy source, using charging systems	8
1.1.1.2 Hybrid-electric: batteries in combination with another onboard source of energy ...	9
1.1.1.3 Plug-in hybrid: batteries with a dedicated charging system and in combination with another onboard source of energy	9
1.1.1.4 List of selected installed battery ESS	10
1.1.2 Charging infrastructure	13
1.1.2.1 Fixed charging	13
1.1.2.2 Swappable battery recharging.....	15
1.1.3 Types of marinized batteries.....	16
1.1.3.1 Battery cells	17
1.1.3.2 Battery systems	17
1.1.4 Battery Management Systems.....	18
1.1.5 Adoption of batteries globally.....	18
1.1.5.1 Increasing battery sizes	19
1.1.5.2 Maritime Battery Manufacturers	21
1.2 Electric Motors, Thrusters and Drives	21
2.0 Hydrogen Propulsion	23
2.1 Fuel Cells.....	24
2.2 Onboard Fuel Storage	29
2.2.1 Liquid Hydrogen	30
2.2.2 Compressed Hydrogen.....	31
2.3 Vessel Approval, Safety and Classification	32
2.4 Hydrogen Bunkering	33
2.4.1 Liquid Hydrogen	34
2.4.2 Compressed hydrogen	37
3.0 Green Hydrogen Production & Infrastructure.....	39
3.1 Production	39
3.2 Large-Scale Storage.....	41

3.3 Transport	42
3.4 Liquid Hydrogen Terminals	44
4.0 Wind Propulsion	46
5.0 Combining Technologies to Achieve Deep Emissions Reductions and Absolute Zero	48
6.0 Crew Training	51
6.1 Electric Systems Training	51
6.2 Hydrogen Training	51
6.3 Wind Propulsion Training	52
7.0 Conclusion	53
References	54
Appendix: Case Studies	Error! Bookmark not defined.

List of Figures

Figure 1: Number of battery power ships per ship type, December 2023 ²	6
Figure 2: Different types of applications for batteries on board ships	7
Figure 3: Percentage of battery propulsion types by year, December 2023 ²	8
Figure 4: Shoreside 10.5 MW charging connection for Aurora af Helsingborg and Tycho Brahe passenger ferries.	14
Figure 5: Harbour trials of offshore charging systems. Left: 1.5 MW charging point to be fixed on an offshore structure (image: MJR Power & Automation). Right: floating buoy charging point (image: Jebb Smith Ltd)	15
Figure 6: Swappable ESS in 20-foot ISO container operational on inland vessel Alphenaar (image: Zero Emission Services)	16
Figure 7: Types of battery chemistries installed per number of ships, September 2022 ²	17
Figure 8: Different types of maritime battery system designs	18
Figure 9: Area of operations of fleet of battery powered vessels, September 2022 ²	18
Figure 10: New operating battery powered vessels by region as a percentage of total per year, September 2022 ²	19
Figure 11: Location of IMO-registered battery powered vessels, January 2023 ²	19
Figure 12: Average installed battery capacity per ship by installation year ²	20
Figure 13: Average installed battery capacity per ship type by year ²	20
Figure 14: Increase in number of maritime battery suppliers in the MBF Ship Register, March 2023 ²	21
Figure 15: Diagram of low-temperature proton exchange membrane (LT-PEM) reaction	24
Figure 16: Examples of commercially available fuel cell modules (left: PowerCell Sweden AB; right: Nedstack). Modules can be serialised for multi-MW power output.	25
Figure 17: Installed fuel cell system nominal power outputs for existing and planned vessels	27
Figure 18: Containerised rack of compressed hydrogen storage tanks (Image: Hexagon Composites ASA).Metal Hydrides	32
Figure 19: Map of hydrogen bunkering locations globally in April 2023 (author's own work).	34
Figure 20: Mobile liquid hydrogen bunkering tower designed and owned by Norled attached to a tube trailer, bunkering the Hydra passenger ferry. Image: Norled AS.	35

Figure 21: Diagram of typical liquid hydrogen bunkering system delivering directly to onboard storage, similar to the system designed and operated by Norled AS for MF Hydra ⁴⁷	35
Figure 22: A ship-to-shore rigid Loading Arm System (LAS) installed in the hydrogen terminal at Port of Kobe, Japan. Credit: HySTRA.....	36
Figure 23: The world's third largest liquid hydrogen tank forms part of an import terminal at Port of Kobe, Japan and can store 178 tonnes ⁸¹ (image: HyTouch Kobe).	42
Figure 24: Liquid hydrogen barges berthed at Stennis Space Center in 1977. Image: NASA/Stennis.	43
Figure 25: The world's first liquid hydrogen carrier Suiso Frontier berthed at a hydrogen terminal in Port of Kobe, Japan. Image: HySTRA.	44
Figure 26: Example of folding rotor sail foundation including the tilting system cylinder. Image: Dealfeng New Energy Technology Ltd.).....	46

List of Tables

Table 1: Summary of Technology Readiness Levels (TRLs) and Commercial Readiness Levels (CRLs) of technologies for electric systems.....	5
Table 2: List of battery ESS installed on vessels by system type (non-exhaustive). References to Case Studies (CS) in the Appendix are given where appropriate. Rows highlighted in yellow are vessels which are under construction or on order as of December 2023.....	10
Table 3: Summary of Technology Readiness Levels (TRLs) and Commercial Readiness Levels (CRLs) of technologies for hydrogen systems	23
Table 4: Technical specifications of LT-PEMFC modules (non-exhaustive). Adapted from Elkafas et al, 2022 ³⁷ . References to Case Studies (CS) in the Appendix given where appropriate.....	26
Table 5: Exhaustive list of publicly announced fuel cell system installations above 100 kW (0.1 MW) capacity, as of December 2023. References to Case Studies (CS) given where appropriate.	28
Table 6: Comparison of liquid hydrogen bunkering systems.....	36
Table 7: List of standards relevant to hydrogen bunkering systems.....	38
Table 8: Summary of Technology Readiness Levels (TRLs) and Commercial Readiness Levels (CRLs) of technologies for green hydrogen production and infrastructure	39
Table 9: Largest liquid hydrogen tanks globally. References to Case Studies (CS) in the Appendix are given where appropriate.....	41
Table 10: Installations of wind propulsion devices by type and vessels, September 2023.	46
Table 11: Summary of Technology Readiness Levels (TRLs) and Commercial Readiness Levels (CRLs) of wind propulsion technologies	47
Table 12: Summary of supplementary technologies to further reduce onboard energy requirements, including Technology Readiness Levels (TRLs) and Commercial Readiness Levels (CRLs)	49

Abbreviations and Definitions

BMS	Battery Management System
CEN	European Committee for Standardization
CS	Case Study
CTV	Crew Transfer Vessel
ESS	Energy Storage System
FC	Fuel Cell
FID	Final Investment Decision
GHG	Greenhouse Gas
ICE	Internal Combustion Engine
IGF Code	International Code of Safety for Ships Using Gases or Other Low Flashpoint Fuels
ISO	International Organization for Standardization
LFP	Lithium-Iron-Phosphate (battery)
LNG	Liquid Natural Gas
LTO	Lithium-Titanate-Oxide (battery)
LT-PEM	Low Temperature Proton Exchange Membrane
NaBH ₄	Sodium Borohydride
NaBO ₂	Sodium Metaborate
NASA	National Aeronautics and Space Administration
NCA	Lithium Nickel-Cobalt-Aluminium Oxide (battery)
NMC	Nickel-Manganese-Cobalt (battery)
RoPax	Roll-on/roll-off Passenger
RoRo	Roll-on/roll-off
SOV	Service Operation Vessel (offshore)
TTW	Tank-to-Wake
VLSFO	Very Low Sulphur Fuel Oil
WTT	Well-to-Tank
WTW	Well-to-Wake

1.0 Electric Systems

Table 1: Summary of Technology Readiness Levels (TRLs) and Commercial Readiness Levels (CRLs) of technologies for electric systems

Technology	TRL/CRL
Battery Energy Storage Systems (ESS) on pure electric vessels	CRL10, up to ~11,000 GT
Battery Energy Storage Systems (ESS) on plug-in hybrid vessels	CRL10, all vessel sizes
Battery Energy Storage Systems (ESS) on hybrid-electric vessels	CRL11, all vessel sizes
Onshore fixed charging systems	CRL10
Offshore fixed charging systems (offshore structure)	TRL7 up to 1.5 MW (expected TRL8 early 2024)
Offshore fixed charging systems (buoy)	TRL7
Swappable battery recharging	TRL/CRL9 to CRL10
Electric propulsion motors	CRL11, up to 41 MW (up to 80 MW on naval vessels)
Electric pod thrusters	CRL11, up to 22 MW
Electric drives	CRL11, up to 30 MW/motor or 50 MW/system

1.1 Marinized Batteries

The first battery powered boats were built in the 19th century¹ but it wasn't until around the year 2000 before the possibilities of battery powered propulsion for ships gained some interest again, beginning with small tourist ferries, often powered by lead-acid or nickel-cadmium batteries². From 2010, the maritime industry started to scale up and commercialise lithium-ion batteries for propulsion.

Electrification is the foundation of absolute zero emission technologies because it enables maximum efficiency, optimisation of wind propulsion and is required for hydrogen-electric fuel cells. A fixed electrical distribution system is the common point for any energy converter and modular propulsion and energy storage systems can be built around it. This way, shipowners have the option to upgrade or retrofit the propulsion system at a later date or transfer the propulsion system to a new vessel when the original vessel reaches the end of its life. Containerised batteries, fuel cells, ICE or generators can easily be swapped out at a later date, for example replacing ICE with hydrogen fuel cells depending on fuel supply³.

In December 2023, there were 831 battery-powered ships in operation and another 353 under construction, amounting to a total battery capacity of 1163 MWh².

Several trends are observable:

¹ ETHW, 'Electric Boats', *Today's Engineer*, 2013 <https://ethw.org/Electric_Boats> [accessed 9 May 2023].

² Marine Battery Forum, 'MBF Ship Register', 2023 <<https://www.maritimebatteryforum.com/ship-register>> [accessed 11 December 2023].

³ Nergard, J., 'Zero Emission Vessel Electrical system integration' in in *ShipZERO28* (London: ZESTAs, 2023) <<https://zestas.org/shipzero28/presentations-gallery/#16>> [accessed 11 December 2023].

- Due to various applications for batteries on board ships, there is a rapid increase in battery powered ships, amongst all different ship types;
- Batteries are an enabler for other zero emission technologies;
- There is a diversification of battery technologies used in the maritime industry and the battery system designs are maturing;
- Increase in number of battery powered ships on a global scale;
- Increase in battery capacity installed per ship;
- Increase in number of maritime battery manufacturers;
- Increased interest in containerized battery solutions.

Today, most ship types can be found with a battery integrated in the propulsion system². The most common ships with batteries installed are car/passenger ferries (see Figure 1), followed by offshore supply ships, fishing vessels, and other offshore vessels.

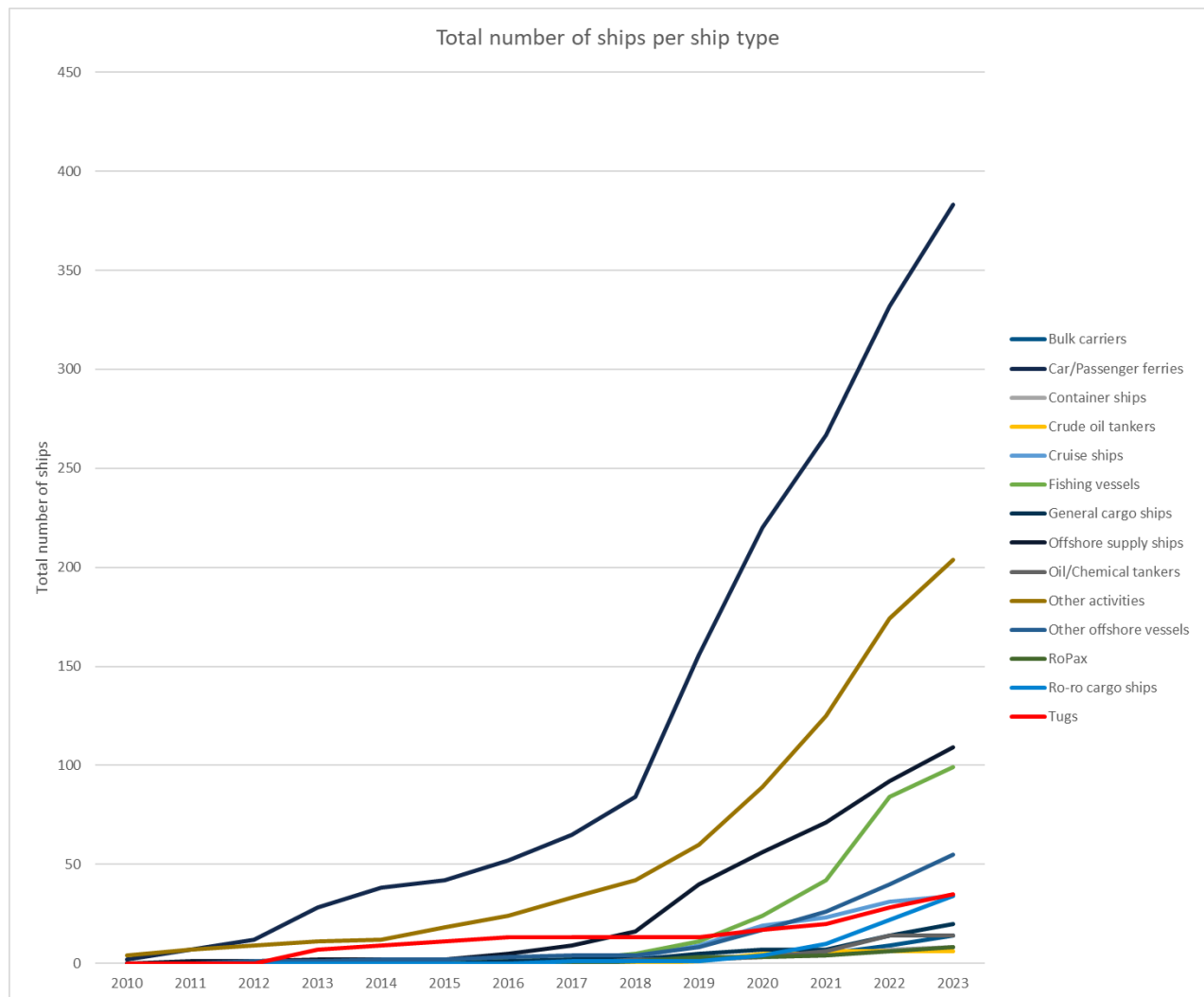

Figure 1: Number of battery power ships per ship type, December 2023²

The main goals for installing batteries are:

- Reducing fuel consumption and costs
- Adding redundancy and safety
- Zero emission sailing
- Increasing energy efficiency
- Reducing maintenance

These goals can be achieved by different ways of using batteries as a part of the propulsion system (see Figure 2):

- Full electric sailing: using only batteries as energy source for propulsion
- Peak shaving: using batteries to reduce the peak loads on generators
- Load levelling: using batteries to run a generator on constant load
- Spinning reserve: using batteries as back-up energy source
- Boost function: using batteries to increase the ship's performance for a short period
- Ramp support: using batteries to increase the response time of the propulsion system
- Black Start: batteries offer a source of “take me home” energy that will prevent ships from going dark in the case of an on-board failure
- Voltage and Frequency regulation: the vessel and all auxiliary equipment onboard will operate for greater periods of time with proper delivery of specific voltage and frequency

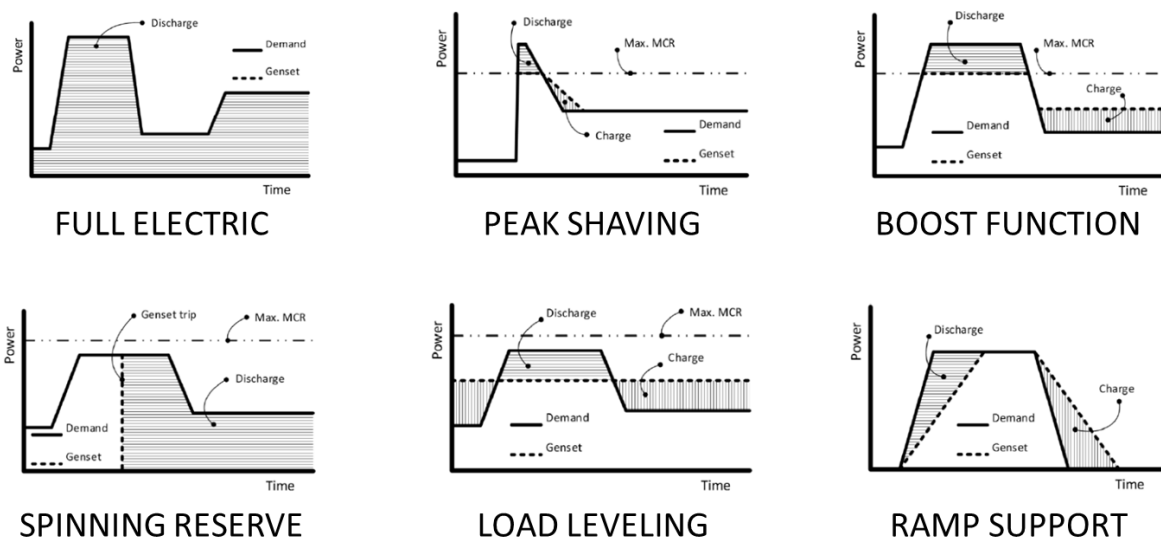

Figure 2: Different types of applications for batteries on board ships

In each case, the batteries form part of electrical Energy Storage Systems (ESS). Almost all classification societies have certification requirements for ESS and specifications for their installation on ships. The first set of provisional rules from a classification society was released in 2013. Additionally, organisations such as IEC have developed relevant standards and are continuously working to improve them.

Globally, over 80% of new builds are now being designed with ESS as of November 2022⁴, indicating the technology has reached CRL11. However, different types of electric systems are applicable for different situations and are not all at the same level of commercialisation, as explained next.

1.1.1 Types of electric systems

There are three main types of electric propulsion configurations:

- Pure electric: only batteries as source of energy with shore charging systems
- Hybrid: batteries in combination with another onboard source of energy

⁴ Clarksons, 'Fleet Electrification to Increase as Marine Battery Technology Becomes Commercially Viable', *Clarksons Securities*, November 2022 <<https://www.clarksons.com/home/news-and-insights/2022/fleet-electrification-to-increase-as-marine-battery-technology-becomes-commercially-viable/>> [accessed 9 May 2023].

- Plug-in hybrid: batteries with a dedicated charging system and in combination with another onboard source of energy

In December 2023, 64% of battery powered vessels were hybrid-electric, followed by pure electric (21%) and plug-in hybrid (15%). Figure 3 shows how this has changed since 2010, with hybrid systems steadily overtaking pure electric, while the proportion of plug-in hybrids has stayed roughly the same².

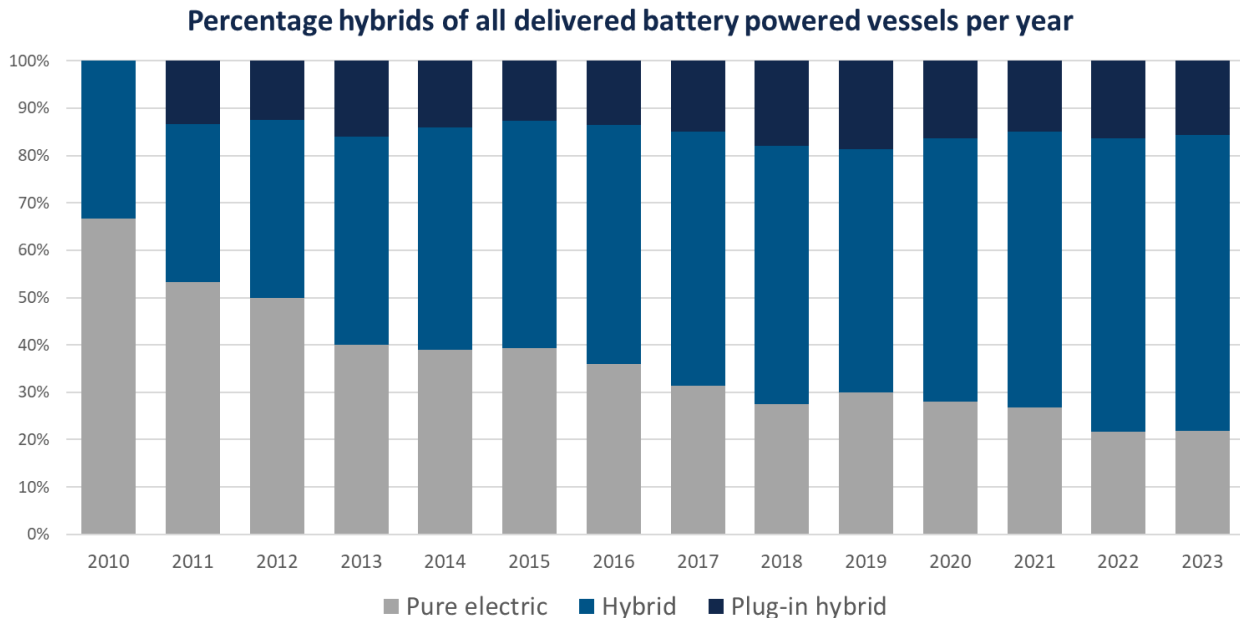

Figure 3: Percentage of battery propulsion types by year, December 2023²

1.1.1.1 Pure electric: only batteries as energy source, using charging systems

A pure electric propulsion system means that only batteries can be used as an onboard energy source. Pure electric vessels are capable of being operated only on isolated short routes whereby the distance to base is defined by the capacity of the ESS system on board, with a significant safety factor. Typically, the vessel would need to demonstrate “take me home” capacity in case part of the system became disabled or needed to be shut off, or in case of fire or other emergency issues that may occur.

There is a segment of the maritime industry that supports pure electric propulsion with a variety of battery types, typically small passenger vessels operating on very short routes within sight of land and support. These markets do not become incorporated into the commercial marine industry verticals due to their inability to meet Flag and Type Approval standards for safe operations of marine craft.

Since the commercialisation of the maritime battery industry in 2010, deployment of fully electric vessels has been a large focus of all operators, Type Approval agencies and Flag authorities, and several vessels have now been built to fully electric operations with strict criteria in place to support all aspects of emergency operations and safety, all typically with a backup source of charging onboard for the emergency situations that would affect safety. Rules concerning “take me home” power have enabled many applications to be built in the context that they will operate fully electric, charge at shore and be able to demonstrate reduced emissions and reduced maintenance costs while ensuring guarantees of safe and risk-free operations. These vessels today tend to be RoPax

ferries, inland waterways, port vessels and ships operating in micro-economies such as high-density island hubs.

In 2023, this market is expanding exponentially with the development of swappable energy systems that allow vessels to become 100% zero emission in operations, whereby the ESS aboard is effectively a fuel source with a very defined operational window. The ability to support applications to become 100% zero emissions in operations is one of the only ways that the marine industry can meet the targets of the IMO Revised GHG Strategy for 2030, 2040 and 2050.

Pure electric vessels are currently at CRL10 but have seen declining proportions of overall battery-powered vessels since 2010 due to their limitation to markets with strict operating parameters, as discussed above. As of December 2023, the largest installed ESS on a pure electric vessel is 6.7 MWh on the 3,000 GT, 120 TEU container ship Yara Birkeland (see Table 2 below and Case Study 1). The largest ESS system on a pure electric vessel under construction is 40 MWh on the 130-metre RoPax ferry provisionally named Incat Hull 096, expected 2025 for Uruguayan ferry operator Buquebús (see Case Study 26). This will be the largest ESS system to be installed on a vessel of any battery propulsion type, and an almost four-fold increase in ESS size compared to the next largest.

1.1.1.2 Hybrid-electric: batteries in combination with another onboard source of energy

In 2010, lithium ESS was introduced to the commercial marine industry in a sizable and scalable capacity, on ships of all sizes. An early driver was to optimize the operations of vessels by putting the power source engines and generators into “constant speed, constant power” mode, where the existing fuel-burning system sees an improvement in efficiency. Fuel-driven systems are operated at constant speed with ESS as the dynamic response to deal with intermittent loads as well as deliver stable power quality, with the ability of the ships to operate either in hybrid or electric or fuel-driven mode.

This means a very significant improvement in performance, GHG impact, maintenance costs, and significantly impacted the risk of 100% uptime positively. Furthermore, the operator’s costs are reduced, legislated targets more easily met, and, very importantly, existing vessels can be quickly converted to hybrid-electric in a cost-effective manner.

Hybrid-electric systems have seen the most adoption in the maritime sector (see Figure 3) and can be regarded as having reached CRL11. Currently, the largest installed ESS on any ship is on hybrid-electric vessels, the 126,000 GT cruise vessels AIDAprima and AIDAprera with 10 MWh storage each⁵ (see Table 2 below).

Hybrid systems include hybrid hydrogen-electric systems, which combine hydrogen fuel cells and battery ESS. These are discussed in more detail in Section 2.1 and some selected installed systems are shown in Table 2.

1.1.1.3 Plug-in hybrid: batteries with a dedicated charging system and in combination with another onboard source of energy

In this model, a hybrid-electric ship has dedicated onshore infrastructure that allows the vessel to rely less on its onboard generation and take advantage of grid power and renewable energy to charge the batteries on board at a significantly reduced cost, while extending the operational life of the vessel in every aspect. Shore charging infrastructure has become a part of the solution, as

⁵ Hansjörg K., ‘AIDAprera Will Receive the Largest Battery Storage System in Passenger Shipping in 2020’, *Carnival Corporation & Plc*, 2019 <<https://www.carnivalcorporation.com/news-releases/news-release-details/aidaperla-will-receive-largest-battery-storage-system-passenger>> [accessed 9 May 2023].

plug-in hybrid vessels have demonstrated the cost and environmental benefits that created a strong demand for adoption. As of December 2023, the largest ESS system on a plug-in hybrid vessel is 5 MWh capacity installed on the 27,000 GT cruise ship Color Hybrid, operational since 2019⁶ (see Table 2 below).

1.1.1.4 List of selected installed battery ESS

Below is a non-exhaustive selection of existing battery ESS installed on vessels, both fully electric and hybrid-electric, listed by battery storage capacity (MWh). Diesel-electric generators (or gensets) are not included.

Table 2: List of battery ESS installed on vessels by system type (non-exhaustive). References to Case Studies (CS) in the Appendix are given where appropriate. Rows highlighted in yellow are vessels which are under construction or on order as of December 2023.

Battery ESS		Vessel						
Size (MWh)	Installation type	Name	IMO number	Type	Gross tonnage (GT)	Operational with batteries since	Charging power (MW)	Characteristics
Pure electric								
40	Newbuild	Incat Hull 096 Buquebús [CS26]		RoPax (ferry)		2025		2,100 passengers and crew, 225 cars, 130m length
11.3	Newbuild	Unnamed		RoPax (ferry)		2025		195m length
11.3	Newbuild	St Malo		RoPax (ferry)		2024		195m length
10	Newbuild	E/V Futura		RoPax (ferry)		2025		1200 lane metres, 140 passengers, 147.4m length
6.7	Newbuild	Yara Birkeland [CS1]	9865049	Container	3,000	2022		Fully autonomous, 120 TEU, 80m length
6.345	Retrofit	MF Tycho Brahe ⁷	9007116	RoPax (ferry)	11,148	2021	10.5	1,250 passengers, 240 cars, 111.2m length
6.2	Newbuild	eWolf		Tug		2023		70 BP, 25m length
5.288	Newbuild	HaiSea Brave	9942988	Tug	472	2023		70 BP, 28.4m length
5.288	Newbuild	HaiSea Wee'Git ⁸	9942976	Tug	472	2023		70 BP, 28.4m length
5.288	Newbuild	HaiSea Wamis	9942964	Tug	472	2022		70 BP, 28.4m length

⁶ Color Line, 'Color Line Fleet', 2019 <<https://www.colorline-cargo.com/color-line-fleet>> [accessed 4 December 2019].

⁷ Corvus Energy, 'MF Tycho Brahe', *Projects*, 2023 <<https://corvusenergy.com/projects/tycho-brahe/>> [accessed 12 May 2023].

⁸ Ross, M., 'Sanmar Shipyards delivers second electric tugboat', *UKI Media & Events*, 18 August 2023 <<https://www.electrichybridmarinetechology.com/news/ferries-and-cruises/sanmar-shipyards-delivers-second-electric-tugboat.html>> [accessed 13 December 2023].

4.6	Newbuild	Wolfe Islander IV [CS2]	9873149	RoPax (ferry)	1,754	2021		Ice Class 1A, 399 passengers & 80 cars, 98.4m length
4.3	Newbuild	Ellen [CS3]	9805374	RoPax (ferry)	996	2019	3.9	198 passengers, 31 cars or 5 HGV trucks & 8 cars, 59.4m length
4.16	Retrofit	M/S Aurora af Helsingborg [CS4]	9007128	RoPax (ferry)	10,918	2017	10.5	111.2m length
3.48	Newbuild	Asahi ⁹	9952270	Bunker ship	492	2022	0.348	Capacity 1,280 cbm, 62m length, range 100 km
2.983	Newbuild	Herjólfur IV [CS5]	9865221	RoPax (ferry)	3,480	2021		84m length
2.8	Newbuild	Sparky (RSD-E-Tug 2513) ¹⁰	9909699	Tug	320	2022	1.4	70 BP, 25m length, 12 knots speed
	Newbuild	Gisas Power IV [CS7]	9947847	Tug	282	2023	2.9	45 BP, 27m length, 10 knots speed
2.214	Newbuild	Gisas Power III [CS7]	9947835	Tug	107	2022	1.85	30 BP, 18.70m length, 10 knots speed
2	Retrofit	Alphenaar		Inland container	n/a	2021		90m length
1.424	Newbuild	Gisas Power II [CS7]	9947823	Tug	107	2022	1.85	30 BP, 18.70m length, 10 knots speed
1.9	Newbuild	Amherst II [CS2]	9873137	RoPax (ferry)	1,230	2021		Ice Class 1A, 300 passengers & 40 cars, 71.7m length
1.582	Newbuild	Nesvik [CS6]	9887528	RoPax (ferry)	2,840	2020		82.4 m length
1.424	Newbuild	Gisas Power ZEETUG30 [CS7]	9876529	Tug	104	2019	1	30 BP (80BP under construction), 18.70m length, 10 knots speed
1.017	Newbuild	Oslofjord I [CS8]	9914448	RoPax (ferry)	457	2021		35m length
0.5	Newbuild	Salicornia	n/a	Rupa (ferry)		2023		Swappable battery system, 260 passengers, 19 cars, 37m length
0.42	Newbuild	Hydromover [CS28]		General cargo	80	2023	0.47	Swappable battery system, 25 tonnes cargo capacity

⁹ Reuters, 'Japan's Asahi Tanker to Start Ship Fuelling with World's First Electric Tanker', *Reuters*, 14 April 2022 <<https://www.reuters.com/article/japan-marine-electric-tanker-idUKL3N2WB3NF>> [accessed 9 May 2023].

¹⁰ Echandia, 'What Batteries Are Used in Sparky the Tugboat?', *Echandia Insights*, October 2022 <<https://echandia.se/insights/article/what-batteries-are-used-in-sparky-the-tugboat/>> [accessed 12 May 2023].

Hybrid-electric								
11.3	Newbuild	SAINT-MALO		RoPax (ferry)		2024		1,000 passengers, 2,571 lane metres, 194.7m
11.3	Newbuild	SAINT-MALO sister (Marine Atlantic W0279)		RoPax (ferry)		2024		1,000 passengers, 2,571 lane metres, 194.7m
10	Newbuild	Scandilines PR24		RoPax (ferry)		2024		140 passengers, 1,200 lane meters, 147.4m length
10	Retrofit	AIDAprima ⁶	9636955	Passenger (cruise)	125,572	2022	n/a	300m length
10	Retrofit	AIDAprila ⁶	9636967	Passenger (cruise)	125,572	2020	n/a	300m length
8.8	Newbuild	P&O Liberte		RoPax (ferry)	47,394	2024	n/a	1,500 passengers, 3,600 lane metres, 231m length
8.8	Newbuild	P&O Pioneer	9895161	RoPax (ferry)	47,394	2023	n/a	1,500 passengers, 3,600 lane metres, 231m length
6.102	Newbuild	Havila Castor [CS6]	9865582	Passenger (cruise)	15,812	2022	n/a	640 passengers, can sail up to 4 hours on pure battery power, 122.7m length,
5.469	Newbuild	MS Cruise Barcelona [CS6]	9351476	RoPax (cruise)	54,310	2019	n/a	3660 passengers, 300 cars, 254m length
5.1	Newbuild	Eco Valencia ¹¹	9859533	RoRo Cargo	67,311	2020	n/a	7,800 lane metres, 238m length
2.2	Newbuild	Aurora Botnia ¹²	9878319	RoPax (ferry)	24,036	2021	n/a	1,500 lane metres, 800 passengers, 20 knots speed
2.034	Retrofit	North Sea Giant [CS6]	9524073	Offshore Construction Vessel	18,151	2018	n/a	153.6m length
1.356	Newbuild	MF Hydra [CS9]	9887530	RoPax (ferry)	2,699	2023	n/a	299 passengers, 80 cars, 80.2m length
Hydrogen-electric								
1.356	Newbuild	MF Hydra [CS9]	9887530	RoPax (ferry)	2699	2023	0.88	299 passengers, 80 cars, 80.2m length

¹¹ Hansen, K. E., 'Jinling Delivers World's Greenest Ro-Ro Ship', *News*, 2020 <<https://www.knudehansen.com/news/jinling-delivers-worlds-greenest-ro-ro-ship/>> [accessed 12 May 2023].

¹² 'In Pictures: Azipod® Propulsion Installed on Wasaline's New Ferry in Just One Week | ABB' <<https://new.abb.com/news/detail/67578/in-pictures-azipod-propulsion-installed-on-wasalines-new-ferry-in-just-one-week>> [accessed 10 May 2023].

1	Retrofit	Skulebas		Fishing training		2024		35m length
0.55	Retrofit	H2 Barge 1 [CS9]		Inland container	-	2023	0.8	192 TEU, 110m length
0.682	Retrofit	FPS Waal (H2 Barge 2) [CS9]		Inland container	-	2024	1	200 TEU
Plug-in hybrid								
5	Newbuild	Color Hybrid ⁶	9824289	Passenger (cruise)	27,164	2019	6.5	2,000 passengers, 500 cars, 160m length
0.994	Newbuild	Stellamar	9951836	General cargo	4135	2023	1.22	Ice class 1A, 90m length
0.994	Newbuild	Electramar	9951824	General cargo	4135	2023	1.22	Ice class 1A, 90m length

Key takeaways:

- Battery ESS are installed up to double-digit MWh capacities. Installed capacities are similar for pure electric and hybrid-electric vessels.
- Vessel sizes vary, but most pure electric vessels are small to medium in size (approximately 11,000 GT and under) while hybrid-electric vessels are larger.
- Ship types of pure electric vessels tend to be passenger vessels but also include tugs up to 70 Bollard Pull¹⁰, a bunker ship (1,280 cbm capacity Asahi⁹ and a container ship (120 TEU capacity Yara Birkeland [Case Study 1]).
- Installations are both retrofits and newbuilds.

1.1.2 Charging infrastructure

Pure electric and plug-in electric vessels require a method of charging and a source of charging energy. Renewable electricity ensures absolute zero GHG emissions. Vessels can charge either at shore, offshore or in swappable batteries. Each will be discussed in detail here.

1.1.2.1 Fixed charging

The integration of fixed charging facilities provides a unique opportunity that allows for an optimised use of space and resources. Fixed charging stations need to be integrated with a substation that converts AC power into DC power required by the batteries. This fairly straightforward integration would also ensure that the batteries are charged faster and more efficiently as DC power produces little to no efficiency loss.

Fixed charging stations are commercially available at a range of power outputs. The charging power required by pure electric vessels in Table 2 (section 1.1.1.4) ranges from 1 MW for smaller ships to 10.5 MW for the ferries MV Tycho Brahe and M/S Aurora af Helsingborg (see Figure 4). The latter vessels are charged with automatic connections at each end of the Helsingborg-

Helsingør route¹³. It takes 5 to 9 minutes to charge the 1.2 MWh of energy needed for one 4-km crossing. Other charging systems are commercially available up to 23 MW [Case Study 10].



Figure 4: Shoreside 10.5 MW charging connection for Aurora of Helsingborg and Tycho Brahe passenger ferries.

However, charging systems are limited by infrastructure development. Infrastructure is a substantial barrier, as it can cost a significant amount of money to bring power to a location that has not needed it, and/or over long distances, with very long paybacks and no real tangible ability to expand networks enough to improve efficiency.

If existing generation exists at the point of vessel use, this problem can be overcome by building fixed land-based battery ESS, which can constantly absorb charge from existing power sources and rapidly transfer the energy to vessels when they are in port. This overcomes the high cost of building permanent infrastructure and gives the operator the choice of either relying on existing power or building local sources of renewable energy to charge the land-based ESS in preparation of arrival and fast turnaround of local vessels. In this model, costs can be reduced and short-term payback realised.

Renewable charging energy is legally required in some cases by the vessel operator. This has led to the deployment of local renewables and microgrids, as well as negotiations with existing infrastructure parties to purchase renewable energy by arbitrage.

Offshore charging is in development, with prototypes having successfully undergone harbour trials (TRL7) with Crew Transfer Vessels (CTVs) in 2023 (see Figure 5). Charging offshore can be delivered either from an offshore structure, such as a turbine or substation, or from a floating buoy. Charging at 1.5 MW from an offshore structure successfully underwent harbour trials by MJR Power & Automation in March 2023¹⁴ and is expected to be actively commissioned at an offshore wind

¹³ ABB, 'Largest Emission-Free Electric Ferries for ForSea', *ABB Marine & Ports - Marine References*, 14 November 2018 <<https://new.abb.com/marine/marine-references/forsea>> [accessed 4 December 2019].

¹⁴ WorkBoat 365, 'MJR Power and Automation - Worlds First "In Air" Offshore Vessel Charging System Completes Successful Harbour Trials', *WorkBoat 365*, March 2023 <<https://workboat365.com/power-propulsion-news/mjr-power-and-automation-worlds-first-in-air-offshore-vessel-charging-system-completes-successful-harbour-trials/>> [accessed 10 May 2023].

farm in early 2024¹⁵. Charging from a floating buoy was successfully trialled in harbour by Oasis Marine in Peterhead, UK, in November 2023¹⁶ and is also expected to be tested by Stilstrom in early 2024¹⁷. Both methods enable range extension and standby power for electrified offshore vessels such as CTVs and Service Operation Vessels (SOVs). By directly charging at an offshore wind turbine, renewable electricity is ensured.



Figure 5: Harbour trials of offshore charging systems. Left: 1.5 MW charging point to be fixed on an offshore structure (image: MJR Power & Automation). Right: floating buoy charging point (image: Jebb Smith Ltd)

Offshore charging has been highlighted by industry as crucial for enabling pure electric SOVs¹⁷. A design for a pure electric 70m SOV was published in November 2023 (SOV 7017 E), with a 15 MWh battery that is expected to charge in “a few hours” on a single offshore wind turbine (see Case Study 27)¹⁸.

The deployment of pure electric and plug-in electric vessels has led to the commercialisation of high-power charging infrastructure that can deliver very fast charging (as fast as 5 minutes) and take into account the safety and operational requirements and complexities of the marine industry.

The fixed battery market is supported largely by fixed infrastructure such as crane operated charging connections or cable reel charging connections, with the focus on autonomous connections to improve safety and reliability. The downside of this approach is that the need for fast charging will decrease the life of the battery, and increase the cost/kWh as a result, but it does meet the need of a vessel to operate on a specific schedule which is critical for managing obligations and meeting revenue needs.

1.1.2.2 Swappable battery recharging

Swappable battery systems simplify infrastructure requirements because batteries are charged away from the vessel, with the ability to physically remove and replace the ESS on board. This allows for a fast transition of the vessel itself, decreasing the time required to provide the ship with a fully charged battery. Furthermore, charging can be optimised to reduce the cost/kWh. Swappable batteries also enable a business case for energy-as-a-service, shifting the cost for the shipowner from the CAPEX to the OPEX. An example of such a system is given in Case Study 11.

¹⁵ Reilly, R., ‘Marine Offshore Energy’, in *ShipZERO28* (London: ZESTAs, 2023) <<https://zestas.org/shipzero28/presentations-gallery/#11>> [accessed 12 December 2023]

¹⁶ Baker, E., ‘Oasis Marine transfers power through its Oasis Power Buoy to a crew transfer vessel’, *UKI Media & Events*, 23 November 2023 <<https://www.electrichybridmarinetechnology.com/news/battery-technology/oasis-marine-transfers-power-through-its-oasis-power-buoy-to-a-crew-transfer-vessel.html>> [accessed 12 December 2023].

¹⁷ Marine Battery Forum, ‘Offshore charging is key for all-electric OSVs’, *News*, 1 November 2023 <<https://www.maritimbatteryforum.com/news/offshore-charging-is-key-for-all-electric-osvs>> [accessed 12 December 2023].

¹⁸ Buljan, A., ‘Damen Launches World’s First Fully Electric SOV Capable of Charging Offshore at OEEC 2023’, *Navingo*, 28 November 2023 <<https://www.offshorewind.biz/2023/11/28/damen-launches-worlds-first-fully-electric-sov-capable-of-charging-offshore-at-oeec-2023/>> [accessed 12 December 2023]

A number of manufacturers commercially supply swappable batteries, including EST-Floattech, Fleetzero, Furukawa & Eco Marine Power, SEAM, Shift Clean Energy (see Case Studies 11 & 28), Wärtsilä and Zero Emission Services. Many suppliers offer energy as a service, having set up pay-per-use contracts for shipowners that include maintenance, eliminating CAPEX and reducing OPEX by up to 77%¹⁹. Some suppliers have integrated swappable ESS of up to 2.1 MWh capacity into standard ISO containers, facilitating retrofit integration and quayside handling²⁰. Swappable battery technology has so far seen limited uptake and is currently at CRL9.

Standards for containerised batteries are not yet developed. Marine Battery Forum, in a Joint Industry Project with leading battery suppliers, published a detailed guideline for the standardisation of containerised batteries²¹. Standardisation would be especially beneficial for swappable applications.



Figure 6: Swappable ESS in 20-foot ISO container operational on inland vessel *Alphenaar* (image: Zero Emission Services).

1.1.3 Types of marinized batteries

The system price for maritime batteries compared to battery systems used in the automotive industry is higher, at a price between 400 €/kWh (436 \$/kWh) and 1000 €/kWh (1090 \$/kWh)²². The main reasons for this are:

- Lower production volume of maritime battery systems
- Higher flexibility required in system design, increasing the complexity for standardisation and large scale manufacturing
- Higher safety requirements for maritime battery systems

¹⁹ Yulu PR, 'Shift Clean Energy's PwrSwäp Technology to Be Used in First All-Electric Vessel in One of the World's Busiest Ports', *Shift Clean Energy*, 28 September 2022 <<https://shift-cleanenergy.com/2022/09/28/shift-clean-energys-pwrswap-technology-to-be-used-in-first-all-electric-vessel-in-one-of-the-worlds-busiest-ports/>> [accessed 10 May 2023].

²⁰ Zero Emission Services, 'Charging Infrastructure', 2023 <<https://zeroemissionservices.nl/en/charging-infrastructure/>> [accessed 10 May 2023].

²¹ Marine Battery Forum, 'Guideline to Standardisation of Containerized Maritime Battery Systems' <<https://www.maritimebatteryforum.com/news/guideline-towards-standardisation-of-containerized-maritime-battery-systems/>> [accessed 10 May 2023].

²² ten Cate Hoedemaker, S., *Solutions for Large Batteries for Waterborne Transport*, 2021.

The higher safety requirements for maritime battery systems are mainly related to the risk of thermal runaway (battery cell self-ignition) propagation. Ships have unique performance and safety requirements which need to be managed in the physical design of the battery and the software that manages the battery. To manage this risk, the design, manufacture and service requirements of marine systems have a higher standard of execution. It is not acceptable to have any cell propagation within a Lithium ESS system. Type Approval Agencies are all improving not only the design criteria, but also industry knowledge on how to safely incorporate ESS into ships and guide improvements that industry requires to reduce risk of failure.

1.1.3.1 Battery cells

The basic building block of a battery system is the battery cell. Currently, only lithium-ion battery cells are being used in the maritime industry, but there are many types of lithium-ion battery cells. At first lithium-ion batteries of the lithium nickel-cobalt-aluminium oxide (NCA) and lithium-iron-phosphate (LFP) chemistry were being used but starting in 2013 it was predominantly nickel-manganese-cobalt (NMC) type of lithium-ion batteries. In more recent years, there is an increased trend in LFP and lithium-titanate-oxide (LTO) type lithium-ion batteries on top of the majority of NMC (see Figure 7). This is for one part the result of an increased understanding of the different characteristics of various lithium-ion battery chemistries and why some are better for specific applications than others.

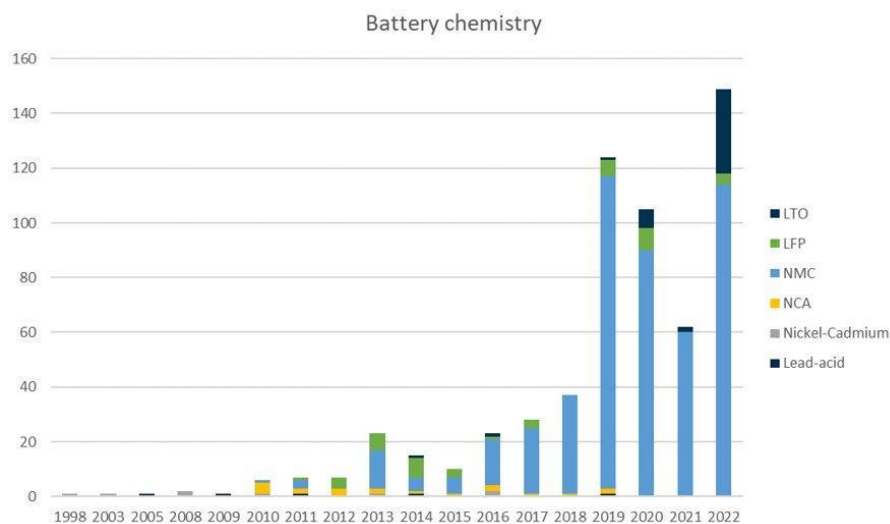

Figure 7: Types of battery chemistries installed per number of ships, September 2022²

The diversification of battery types will continue to develop where batteries become more specialised for applications that require a very high energy density, heavy duty applications, increased safety, or extreme low-cost batteries. This will happen with new types of lithium-ion batteries, but also other battery technologies currently under development.

1.1.3.2 Battery systems

There are different types of maritime battery system designs. Modular and tray-based systems are designed for flexibility of installation on board ships. Rack and block-based systems are designed for easy integration. Details and specification data for a selection of marinized battery systems are given in Case Studies 12 to 14.

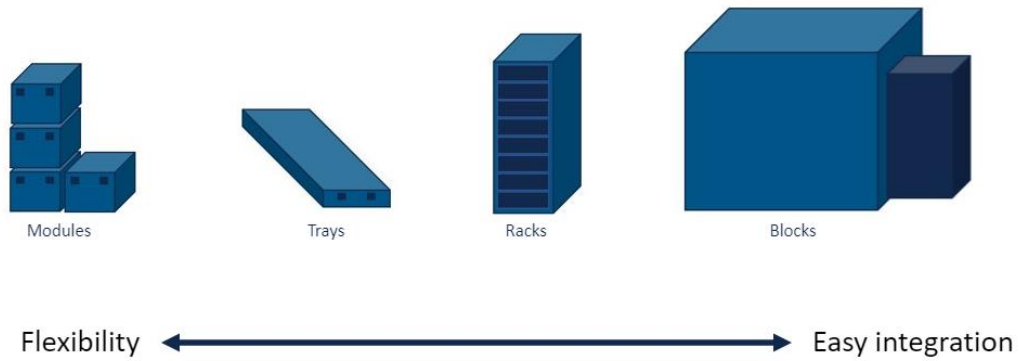

Figure 8: Different types of maritime battery system designs

1.1.4 Battery Management Systems

The Battery Management System (BMS) is very important for a high-quality battery system. The BMS takes care of six main functions:

- Management
- Risk Mitigation
- Monitoring
- Computation
- Communication
- Protection

BMS are being deployed rapidly and increasing in complexity. Besides providing safety, newly developed functions for the BMS are increasing the lifetime of batteries and monitoring operational efficiency of the vessel.

1.1.5 Adoption of batteries globally

In 2022, about half of battery powered vessels operated in Norway, with the rest of Europe making up a quarter and Asia 14%² (see Figure 9 and Figure 11). Norway and Asia (especially China) were the fastest growing regions for the adoption of battery powered vessels during 2021-22² (see Figure 10).

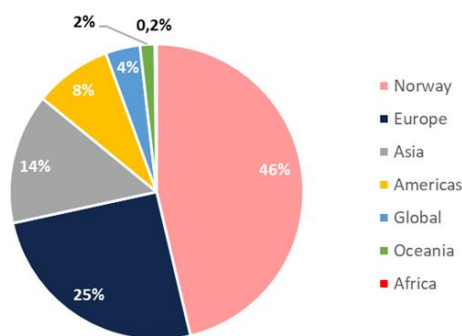

Figure 9: Area of operations of fleet of battery powered vessels, September 2022²

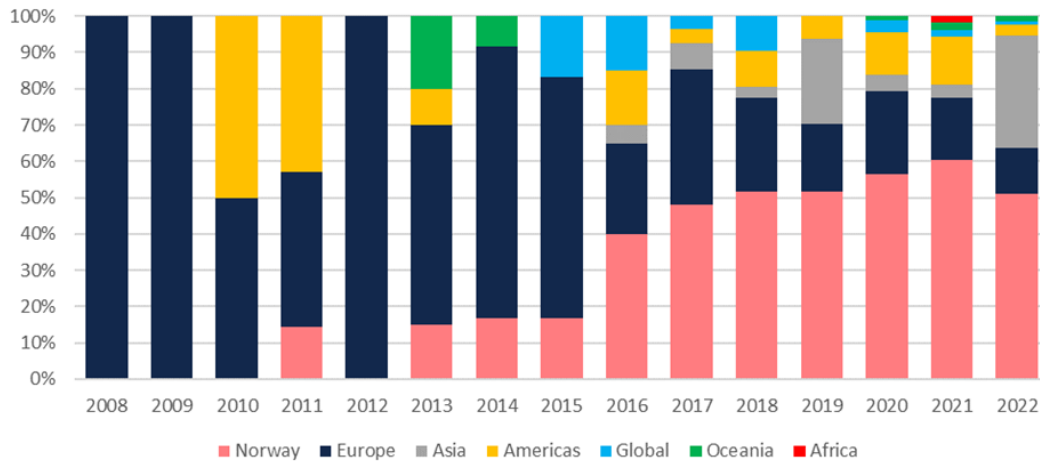

Figure 10: New operating battery powered vessels by region as a percentage of total per year, September 2022²

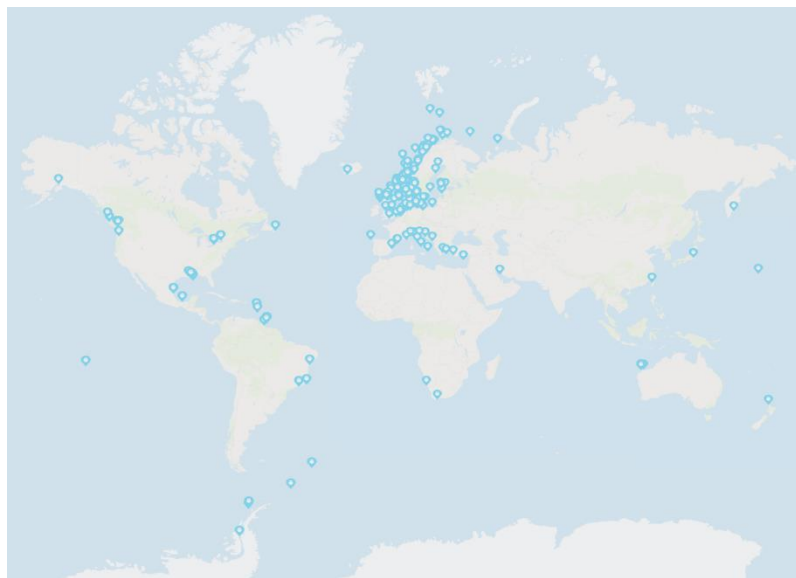

Figure 11: Location of IMO-registered battery powered vessels, January 2023²

1.1.5.1 Increasing battery sizes

The average capacity of battery systems installed on ships shows a growing trend (see Figure 12)². Between 2010 and 2016 it varied from an average installed capacity per ship between 200 kWh and 500 kWh. In 2022 this has increased to 1,200 kWh (1.2 MWh) average installed battery capacity per ship. The largest battery system installed on board a ship in 2022 is around 10 MWh, AIDaperla and AIDAprima⁶. Ships with a larger battery capacity are expected, for instance two RoRo ferries for Stena currently under construction with 11.2 MWh each²³ and the Incat Hull 096 passenger ferry with 40 MWh of battery capacity (see Case Study 26).

²³ Shippax, 'Leclanché Receives Orders for 22.6 MWh of Battery Systems with Stena RoRo for Two E-Flexers', *Shippax*, January 2023 <<https://www.shippax.com/en/news/leclanche-receives-orders-for-226-mwh-of-battery-systems-with-stena-line-and-brittany-ferries-for-two-e-flexers.aspx>> [accessed 10 May 2023].

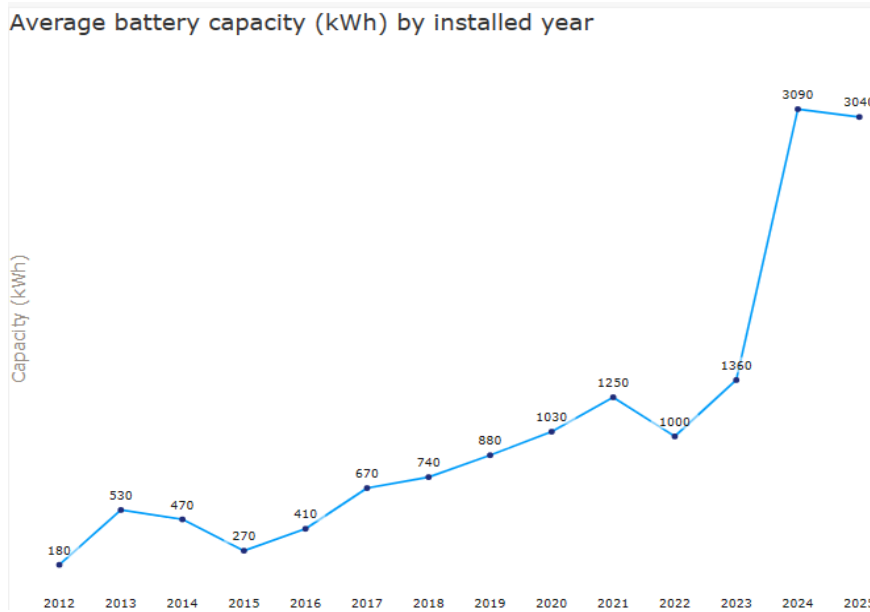

Figure 12: Average installed battery capacity per ship by installation year^{2,24}

The largest battery systems on average can be found on RoPax ships (about 3.25 MWh average per ship), Ro-Ro cargo ships (about 2.25 MWh), cruise ships (about 1.75 MWh), tugs and container ships (both about 1.25 MWh) (see Figure 13).

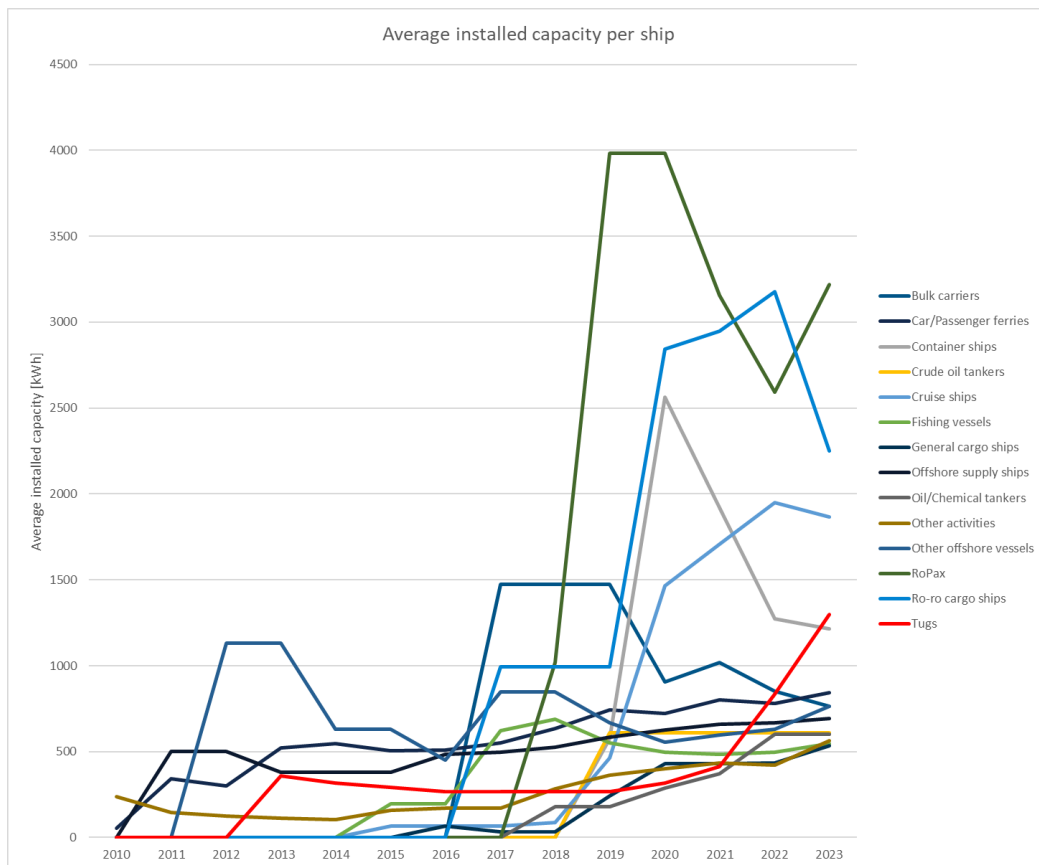

Figure 13: Average installed battery capacity per ship type by year²

²⁴ The results in the figure above for 2024 and 2025 are biased because larger vessels are announced at an earlier stage, therefore the vessels in the MBF Ship Register that are planned for 2024 and 2025 do not represent an accurate average for these years. Nonetheless, the trend of increased battery size installed on vessels is expected to increase over time.

1.1.5.2 Maritime Battery Manufacturers

The number of manufacturers of maritime battery systems is increasing². There are different types of manufacturers producing maritime battery systems:

- Battery cell manufacturers who also integrate their cells into maritime systems
- Manufacturers who source battery cells to integrate them into battery systems for multiple industries
- Manufacturers who source battery cells to integrate them into battery systems dedicated to the maritime industry
- Electrical integrators in the maritime industry with their own developed maritime battery system

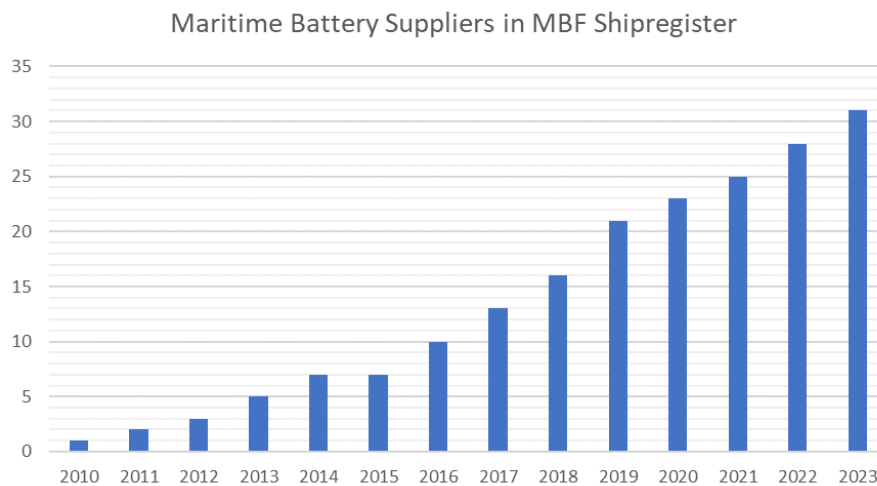

Figure 14: Increase in number of maritime battery suppliers in the MBF Ship Register, March 2023²

1.2 Electric Motors, Thrusters and Drives

Electric motors provide the rotational energy needed by the propellers for propulsion. Motors are an established technology in the marine sector, commercially available up to 40 MW power output²⁵ and can be added in series for greater total propulsion power output. The greatest motor power output installed on a commercial vessel as of March 2023 is 41 MW on the cruise ship *Quantum of the Seas*²⁶ and the greatest installed power delivered on any vessel to date is 80 MW on *Queen Elizabeth Class* aircraft carriers²⁷. Electric motors are at CRL11, being commercialised on thousands of vessels and readily available.

Azimuth thrusters are electric drive motors in submerged pods outside the ship's hull able to rotate 360 degrees. These thrusters are available up to 22 MW propulsion power each²⁸. They provide increased manoeuvrability, higher efficiency and operation time gains compared to standard fixed motor designs and can be installed as retractable units. They can be installed both on fully electric vessels and on hybrid vessels as auxiliary propulsion. For example, the hybrid electric *RoPax* ferry *Aurora Botnia* is equipped with two 5.8 MW electric pod thrusters¹². Like fixed electric motors, thrusters are commercialised and established technology (CRL11).

²⁵ General Electric, 'GE Power Conversion - Advanced Induction Motor (AIM)', *GE Power Conversion*, 2023 <<https://www.gepowerconversion.com/product-solutions/induction-motors/Advanced-Induction-Motor-AIM>> [accessed 10 May 2023].

²⁶ ABB, 'Quantum of the Seas', *ABB Marine & Ports - Marine References*, 2023 <<https://new.abb.com/marine/marine-references/quantum-of-the-seas>> [accessed 10 May 2023].

²⁷ ABB, 'Quantum of the Seas'.

²⁸ ABB, 'Azipod Electric Propulsion', *ABB Marine & Ports*, 2023 <<https://new.abb.com/marine/systems-and-solutions/azipod#highice>> [accessed 10 May 2023].

Drives are electronic hardware that provide the frequency (Hz) and revolutions per minute (RPM) to an electric motor or thruster. They also form part of the electrical system that manages the power management systems on board. Drives are available scaled up to 30 MW per motor or 50 MW per system²⁹. Drives are used in hybrid-electric and fully electric vessels for power conversion, motor control and integration of power sources such as batteries or fuel cells. They are one of the enabling technologies that system integrators combine to build zero emission vessels. Drives are mature technology that is readily available across the marine sector (CRL11).

²⁹ Stadt AS, 'Lean Drive', Stadt AS, 2023 <<https://www.stadt.no/lean-drive>> [accessed 10 May 2023].

2.0 Hydrogen Propulsion

Maritime hydrogen propulsion was first demonstrated in the 2000s with passenger vessels sailing in Hamburg (FCS Alsterwasser) and Amsterdam (NemoH2), both equipped with Low Temperature Proton Exchange Membrane Fuel Cell technology (LT-PEMFC)³⁰. Since then, technology has evolved, demonstrating multi-MW application in stationary and various small crafts with hydrogen fuel cells. Table 3 shows the TRLs and CRLs of hydrogen propulsion technology and associated infrastructure.

It was not until the Paris Agreement in 2016 that hydrogen was recognized as a key to the energy transition. When used in fuel cells, hydrogen has no direct Greenhouse Gas (GHG) emissions from tank-to-wake (TTW). When produced using electricity from renewable sources, hydrogen is an energy source without direct GHG emissions across the full well-to-wake (WTW) lifecycle, according to the MARIN NL Model for ESSF SAPS³¹. Investments in hydrogen have ramped-up ever since, including in the maritime application with significant funding of technology development, demonstration, and deployment. Information on hydrogen propulsion development is non-exhaustive since many projects are confidential.

Equipment for hydrogen propulsion, as well as for the onboard storage and bunkering of both gaseous and liquid hydrogen, are all commercially available and class-approved³². All relevant systems are explained in detail in this section.

Table 3: Summary of Technology Readiness Levels (TRLs) and Commercial Readiness Levels (CRLs) of technologies for hydrogen systems

Technology	TRL/CRL
Low temperature PEM fuel cell systems for main propulsion power	TRL/CRL9 on vessels up to 2700 GT
Low temperature PEM fuel cell systems for auxiliary power	TRL/CRL9
Liquid hydrogen onboard storage	TRL/CRL9, up to 4,000 kg with zero BOG
Compressed hydrogen onboard storage	TRL/CRL9, up to 1,000 kg, at 300 to 700 bar
Metal hydride storage	TRL/CRL9
Liquid hydrogen ship-to-shore direct filling (mobile)	TRL/CRL9, up to 3,000 kg/hour
Liquid hydrogen ship-to-shore direct filling (fixed)	TRL/CRL9
Compressed hydrogen ship-to-shore direct filling (fixed)	TRL/CRL9, up to 220 kg/hour
Compressed hydrogen tank/container swapping	TRL/CRL9
Metal hydride bunkering	TRL8

³⁰ International Energy Association, *IEA Hydrogen TCP Task 39: Hydrogen in the Maritime* (Chapter 6: Review of Hydrogen Propelled Vessels: IEA, 2021).

³¹ European Sustainable Shipping Forum, 'Sustainable Power @ MARIN', *European Commission*, 2023 <<https://sustainablepower.application.marin.nl/well-to-wake>> [accessed 10 May 2023].

³² Stave, H., 'Onboard Hydrogen Systems', in *ShipZERO26* (Glasgow: ZESTAs, 2021) <https://vimeo.com/668135738?embedded=true&source=vimeo_logo&owner=158416371> [accessed 10 May 2023].

Hydrogen fuel can be used in internal combustion engines (ICE) for propulsion through direct drives, but this is a 'near zero'-GHG, not 'absolute zero'-GHG, technology, based on the definition laid out in ISWG-GHG 13/3/9. Storage, bunkering and land-based hydrogen infrastructure is identical for ICE and PEMFC-powered vessels. A CTV and two ferries powered by hydrogen-fossil dual fuel ICE have been deployed with up to 90% hydrogen ratio (or 'near zero' GHG emissions) at lighter loads by CMB.Tech³³. A further 5 CTVs and a 65-tonne BP tug are in build as of March 2023. A land-based 100% monofuel hydrogen spark ignition ICE has also been developed with a rated power output of 1 to 2.6 MW but this has yet to be demonstrated onboard a vessel³⁴.

2.1 Fuel Cells

Hydrogen fuel cells for maritime application are commercially available (CRL/TRL9) for main or auxiliary power and are generally based on LT-PEM technology³⁵. LT-PEM has developed in automotive, heavy-duty mobility and industrial stationary applications. A number of vessels of various types powered by hydrogen fuel cells are now in commercial operation.

Hydrogen fuel cell stacks are solid-state scalable modules which when added in series and/or parallel create a hydrogen fuel cell system. The system includes all equipment required for safe and reliable operation including ventilation, cooling, safety systems, control system, power conversion drives and the fuel distribution system. Hydrogen fuel cell systems are combined with battery ESS to optimise energy use and can be regarded as "hybrid hydrogen-electric systems".

Global fuel cell manufacturing capacity was 12 GW in 2023 across all industries, more than half of which is located in South Korea and Japan. For maritime, the majority of fuel cell manufacturers with commercially available products are located in the USA and the EU³⁶.

In a LT-PEM fuel cell, hydrogen reacts with oxygen at a low temperature, omitting any other reactions of air and therefore has no direct harmful GHG, particulate matter (PM) or nitrogen-oxide emissions.

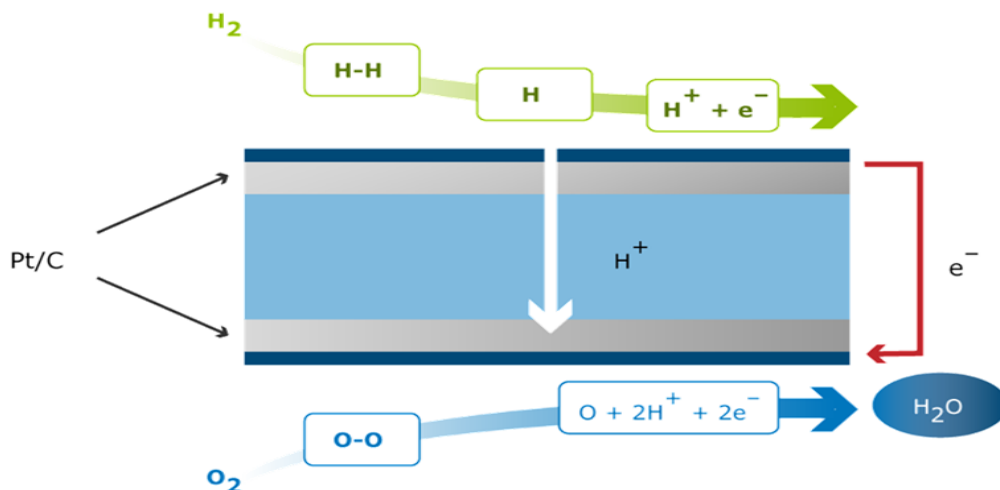

Figure 15: Diagram of low-temperature proton exchange membrane (LT-PEM) reaction

³³ Information from supplier

³⁴ CMB.Tech, 'BEH2YDRO Launches 100% Hydrogen Engines for Heavy-Duty Applications at World Hydrogen Summit in Rotterdam', *CMB.Tech News*, 2023 <<https://cmb.tech/news/beh2ydro-launches-100-hydrogen-engines-for-heavy-duty-applications-at-world-hydrogen-summit-in-rotterdam>> [accessed 10 May 2023].

³⁵ Elkafas, A. G. et al., 'Fuel Cell Systems for Maritime: A Review of Research Development, Commercial Products, Applications, and Perspectives', *Processes* 2023, Vol. 11, Page 97, 11.1 (2022), 97 <<https://doi.org/10.3390/PR11010097>>.

³⁶ McKinsey & Company, *Hydrogen Insights* 2023, September 2023 <<https://hydrogencouncil.com/wp-content/uploads/2023/05/Hydrogen-Insights-2023.pdf>>.

As a result of the reaction, electricity, heat and pure water are produced. The electricity produced by a fuel cell is a variable direct current which is converted by off the shelf power conversion equipment to suit a vessel's electrical grid.

The electrical efficiency of LT-PEM fuel cell modules varies in general between 50-60%, where partial load results in a higher efficiency. This contrasts the efficiency of hydrogen-driven ICE of which the peak efficiency is less than 50%, and in partial load even lower³⁰. As a result, with a fixed amount of stored hydrogen, hydrogen propulsion by LT-PEM fuel cells will have a significantly larger range than ships driven by hydrogen power ICE. The efficiency of LT-PEM fuel cell systems can be further optimised by utilising the heat and water by-products.



Figure 16: Examples of commercially available fuel cell modules (left: PowerCell Sweden AB; right: Nedstack). Modules can be serialised for multi-MW power output.

Marinized fuel cell modules are commercially available up to 500 kW nominal power³⁷. At least 13 manufacturers produce marinized LT-PEM fuel cell modules. Table 4 shows the current marinized LT-PEM suppliers and their products. Detailed specifications for a selection of marinized fuel cell systems are given in Case Studies 15 to 17.

³⁷ Elkafas, A. G. et al., 'Fuel Cell Systems for Maritime: A Review of Research Development, Commercial Products, Applications, and Perspectives', *Processes*, 11.1 (2023) <<https://doi.org/10.3390/pr11010097>>.

Table 4: Technical specifications of LT-PEMFC modules (non-exhaustive). Adapted from Elkafas et al, 2022³⁷. References to Case Studies (CS) in the Appendix given where appropriate.

FC Supplier	Module	Power (kW)	Efficiency (%)	Power Density (kW/tonne)/ (kW/m ³)	Voltage Range/Current Range	Lifetime (h)
Nedstack [CS15]	MT-FTCI-100	100	55	50/27.1	300–600/0–200	24,000–30,000
	MT-FTCI-500	500	55	41.7/14.6	500–1000/0–1200	24,000–30,000
PowerCell	PS Marine 200	200	54	286/138	500–1000/60–450	>30,000
Ballard [CS16]	Fcmove-HD	70	57	280/150	250–500/20–240	-
	Fcmove-HD+	100	57	385/142	280–560/20–360	>20,000
	Fcwave	200	56	229/101	350–720/0–600	>20,000
Genevos	HPM-15	13.5	52	135/54	48	>20,000
	HPM-40	40	54	214/77	230–800	>20,000
	HPM-80	80	55	242/96	400–800	>20,000
Proton Motor	HyStack 200	35.5	47–67	555/380	71–137/0–500	-
	HyStack 400	71	47–67	651/473	142–275/0–500	-
Toyota EODev	REXH2	60	30	150/60	600	13,000
Hydrogenics /Cummins Inc. [CS17]	HyPM-HD 30	33	55	541/500	60–120/0–500	>10,000
	HyPM-HD 90	99	55	302.8/197.2	180–360/0–500	>10,000
	HyPM-HD 180	198	55	302.8/197.2	360–720/0–500	>10,000
Loop Energy	S300-S	28	56	102.2/56.3	370–450/0–300	-
	T505-S	48	55	126.3/64.3	370–450/0–300	-
	T600-S	59	66	151.3/82.6	370–450/0–300	-
Horizon	VL II-M60	60	48	368.1/234.4	250–700/400–550	-
	VLII-M100	100	48	420.2/113.3	250–700/400–550	-
Nuvera	E-45-HD	45	50	240.6/150	290/312.5	-
	E-60-HD	60	50	315.8/200	180/375	-
Troowin Power	TWZFCSZ-60	60	50	177.5/36.7	-	-
	TWZFCSZ-80	80	50	228/49	-	-
Corvus Toyota	Fuel Cell Pack	320	-	128/46.5	-	30,000
Helion	FC-RACK 160	160	57	119.4/47.2	352–672/470	-
	FC-RACK 180	180	57	131.4/53.1	396–756/470	-
	FC-RACK 200	200	57	142.9/59	440–840/470	-

To provide a more cost-effective solution, modules can easily be connected in parallel to a DC or AC grid to supply multi-MW of power with a high level of redundancy. ZESTAs has collected exhaustive data of marine fuel cell systems.

Figure 17 shows fuel cell systems with power capacity 0.1 MW (100 kW) and above which are either already installed on operational vessels, Final Investment Decision (FID) signed or funded with considerable public grants (over 2.5 million EUR per vessel). The expected number of installations in the coming years is greater than what is shown below because many projects are confidential.

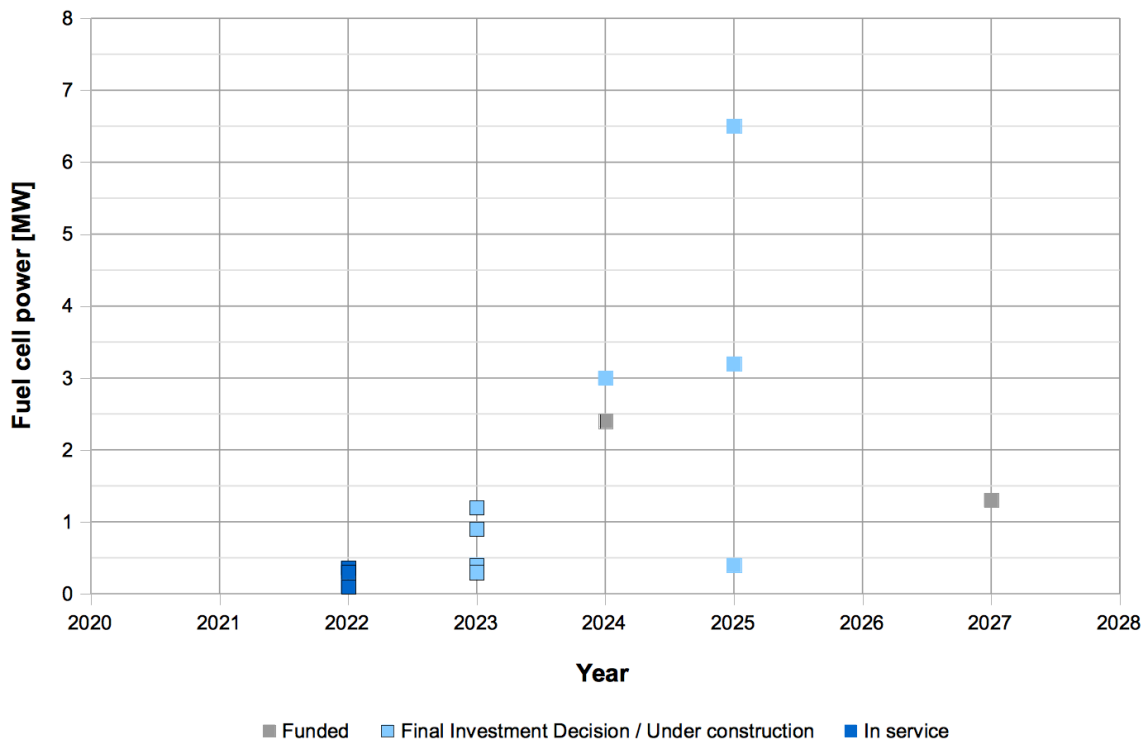

Figure 17: Installed fuel cell system nominal power outputs for existing and planned vessels

Table 5 shows in further detail the data for fuel cell systems shown in Figure 17. Currently, six different suppliers have installed fuel cell systems of 0.1 MW capacity or higher on vessels (Ballard Power, Nedstack, Cummins, PowerCell, Yanmar PT and Proton Motor), with another (Teco 2030) expected by 2024. This includes the HyEkoTank project for retrofit of a product tanker for carriage of compressed hydrogen, which received 5 million EUR from Horizon Europe³⁸, as well as the RH2IWER project for the retrofit of 6 inland vessels of various types which received 15 million EUR in EU funding³⁹. The remaining installations are at FID stage or later based on private investments.

The largest order to date is for two 6.5 MW fuel cell systems for two Torghatten Nord ferries⁴⁰, but larger systems are technically simple to scale up due to the modular nature of fuel cell systems. A design by LH2 Shipping for LMG Marin shows that short sea shipping vessels are technically

³⁸ Teco 2030, 'TECO 2030 with Consortium Finalizes Agreement for EUR 5 Million in HyEkoTank Project', *Teco 2030 News*, December 2022 <<https://teco2030.no/news/teco-2030-with-consortium-finalizes-agreement-for-eur-5-million-in-hyekotank-project-17951173/>> [accessed 10 May 2023].

³⁹ Clean Hydrogen Partnership, 'Renewable Hydrogen for Inland Waterway Emission Reduction (RH2IWER)', *Clean Hydrogen Joint Undertaking*, 2023 <https://www.clean-hydrogen.europa.eu/projects-repository/rh2iwer_en> [accessed 10 May 2023].

⁴⁰ PowerCell Group, 'World's Largest Marine Fuel Cell Systems', 2023 <<https://powercellgroup.com/worlds-largest-marine-fuel-cell-systems/>> [accessed 10 May 2023].

possible using 2-MW hydrogen fuel cells with 15-tonnes liquid storage in combination with wind propulsion (see Case Study 29)⁴¹.

Table 5: Exhaustive list of publicly announced fuel cell system installations above 100 kW (0.1 MW) capacity, as of December 2023. References to Case Studies (CS) given where appropriate.

Case Study FC System(s)	Stage	Number of vessels	FC Supplier	FC System Capacity (MW)	Vessel Type	Gross Tonnage	Operational	Function
Torghatten Nord ferries ⁴⁰	Under construction	2	PowerCell Sweden	6.5	RoPax ferry	< 5000*	2025, October	Main propulsion
SeaShuttle ⁴²	Under construction	2		3.2	Container cargo	~5000*	2025	Main propulsion
Feadship Superyacht Project 821 ⁴³	Sea trials	1	PowerCell Sweden	3	Luxury yacht	> 7000*	2024	Auxiliary power
HyEkoTank project ³⁸	Funded	1	Teco 2030	2.4	Product tanker	~13500*	2024	Auxiliary power
RH2IWER ³⁹	Funded	6	Ballard, Nedstack	0.6-2	Inland container, bulk and tanker	-	2027	Main propulsion
FPS Waal [CS9]	Under construction	1	Ballard	1.2	Inland container	-	2024	Main propulsion
H2 Barge 1 [CS9]	In service	1	Nedstack	0.825	Inland container	-	2023	Main propulsion
With Orca ⁴⁴	Under construction	1		0.8	Bulk carrier	5500	2024	Auxiliary power
Medusa 2	In service	1	Nedstack	0.6	Dredger		2023	Auxiliary power
Hanaria	In service	1	Yanmar PT	0.48	Passenger ferry	240	2023	Main propulsion
Zulu 06 [CS9]	Sea trials	1	Ballard Power	0.4	Inland container	-	2023	Main propulsion
MF Hydra [CS9]	In service	1	Ballard Power	0.4	RoPax ferry	2699	2023	Main propulsion
Sea Change ⁴⁵	In service	1	Cummins	0.36	Passenger ferry	~20*	2022	Main propulsion
Skulebas	Under construction	1		0.32	Fishing training		2024	Main propulsion

⁴¹ Østvik, I., 'The world's first Liquid Hydrogen Ferry to Liquid Hydrogen bulk carriers' in *ShipZERO28* (London: ZESTAs, 2023) <https://zestas.org/shipzero28/presentations-gallery/#19> [accessed 12 December 2023].

⁴² Samskip, 'Samskip Launches Its Next- Generation Zero-Emission Short Sea Container Vessels', *News*, 2023 <<https://www.samskip.com/news/samskip-launches-its-next-generation-zero-emission-short-sea-container-vessels/>> [accessed 12 May 2023].

⁴³ Information from PowerCell Sweden AB

⁴⁴ Information from supplier

⁴⁵ Switch Maritime, 'SW/TCH Maritime', *Projects*, 2023 <<https://www.switchmaritime.com/>> [accessed 12 May 2023].

Antonie ⁴⁶	In service	1	Nedstack	0.3	Inland dry cargo	-	2023	Main propulsion
Elektra ⁴⁷	In service	1	Ballard Power	0.3	Inland push boat	-	2022	Auxiliary power
ZEUS ⁴⁸	In service	1	Proton Motor	0.14	Research	170	2023	Auxiliary power
Viking Neptune ⁴⁹	In service	1	Nedstack	0.1	Cruise	47800	2022	Auxiliary power

* Gross tonnage interpolated from similar vessels.

Key points:

- Hydrogen fuel cell modules are scalable in multi-MW systems. Demonstrators in service at lower power capacity have paved the way for systems on larger commercial vessels.
- Two 6.5 MW fuel cell systems have been ordered for two Torghatten Nord passenger ferries, the largest yet, with FID signed in 2023 and are expected operational in 2025⁴⁰.
- Vessels using hydrogen fuel cells for main propulsion are small to medium in size at about 5,000 GT or below. Systems intended to provide auxiliary power are installed on vessels of any size, from a port dredger to a 930-passenger, 47800 GT cruise ship.
- Ship types of vessels in service are diverse, including RoPax, passenger, cruise, inland cargo, research and dredger. Further ship types of vessels expected to enter service are fishing training, container, yacht, bulk carrier and tanker.
- Installations both in retrofit and newbuild have been demonstrated.

In conclusion, marinized fuel cell modules are commercialised on installed fuel cell systems up to 0.825 MW nominal power, both in newbuild and retrofit, with installations of at least 6.5 MW under construction. However, development is limited to a number of first-of-a-kind vessels (TRL/CRL9).

2.2 Onboard Fuel Storage

The two conventional hydrogen fuel storage options are liquified hydrogen in tanks at cryogenic temperatures and compressed gaseous hydrogen in pressurised tanks⁵⁰. Metal hydride storage has also been demonstrated on a commercial vessel.

Important factors deciding whether compressed or liquefied hydrogen storage onboard is most suitable are⁵⁰:

- Quantity of hydrogen to be stored, mainly as a function of installed power (propulsion and/or auxiliary), load profile, sailing distance and operational/safety reserves;
- Available volume or deck area for installing tanks;
- Bunkering intervals, infrastructure and available time for bunkering operations;
- Economic considerations regarding the cost of gaseous or liquid hydrogen as well as the cost of infrastructure and related maintenance.

⁴⁶ NPRC, 'Minister Harbers Gives Go-Ahead for New Construction of Inland Vessel Propelled by Green Hydrogen', 2023 <<https://nprc.eu/minister-harbers-gives-go-ahead-for-new-construction-of-inland-vessel-propelled-by-green-hydrogen/?lang=en>> [accessed 12 May 2023].

⁴⁷ Argo-Anleg GmbH, 'Lighthouse Project: Canal Push Boat ELEKTRA', *Projects*, 2023 <<https://www.argo-anleg.de/en/project/kanalschubboot-elektra/>> [accessed 12 May 2023].

⁴⁸ Fincantieri SI, 'ZEUS (ZERO EMISSION ULTIMATE SHIP)', *Innovation*, 2023 <<https://www.fincantieri.si/innovation>> [accessed 12 May 2023].

⁴⁹ Fincantieri S.p.A., 'Viking Neptune', 2023 <<https://www.fincantieri.com/en/products-and-services/cruise-ships/viking-neptune/>> [accessed 10 May 2023].

⁵⁰ ZEM Tech, *North Sea Hy-Ships Study Phase 1* (Aberdeen, 2021).

Fuel quantity required onboard is generally the most important factor and is decided by operating distance and expected power. Vessels with larger operated distances are better suited to liquid hydrogen, while those with short point-to-point or frequent return-to-base operations are better suited to compressed hydrogen, regardless of size⁵⁰.

Hydrogen is made usable as a fuel either by compression or liquefaction. Compression to 700 bar, for example, achieves a volumetric energy density of about 1300 kWh/m³. Hydrogen is stored at a variety of pressures depending on the customer's requirements. Liquefying hydrogen increases the volumetric energy density of 2360 kWh/m³ but requires cooling to -253°C. For comparison, the volumetric energy density of VLSFO is 10013 kWh/m³⁵⁰.

Hydrogen storage for delivery to fuel cells follows ISO 14687:2019 or SAE J2719 standards for hydrogen supply purity⁵¹.

2.2.1 Liquid Hydrogen

Onboard storage of liquid hydrogen to power fuel cells onboard a ship was demonstrated in October 2022⁵² and the passenger ferry MF Hydra has operated commercially on liquid hydrogen since March 2023 (TRL/CRL9).

Liquid hydrogen must be stored at -253°C. Advanced knowledge of handling liquid hydrogen for use as rocket fuel has developed across the world since the 1950s in the aerospace sector. For example, NASA and the US Air Force handle millions of tonnes of liquid hydrogen each year⁵³. Liquid hydrogen is also used in other industrial sectors, such as semiconductor manufacturing. In the maritime sector, considerable knowledge and expertise of LNG fuel (which must be stored at -160°C) has been transferred to liquid hydrogen, both being low-flashpoint fuels requiring cryogenic systems for storage.

Onboard pipes for transport of liquid hydrogen are double-walled and vacuum-insulated to counteract significant stress by thermal expansion and shrinkage during fuel transfer and by hull deformation⁵⁴.

Tanks for liquefied hydrogen are similar to LNG tanks, the main differences being the lower storage temperature and material compatibility for hydrogen. Austenitic stainless steels are suitable for extremely low cargo temperatures and prevention of hydrogen leaks⁵⁵.

A liquid hydrogen tank slowly absorbs heat from its environment despite careful insulation and part of the liquid inside evaporates, known as boil-off gas (BOG). To minimise boil-off, tanks are designed to withstand pressures of 5-10 bar. To contain and reuse boil-off gas on the RoPax passenger ferry MF Hydra operated by Norled AS, a small heat inleak to the liquid hydrogen storage removes over-pressure from the gas-phase of the tank and feeds it to the vaporizer producing gas to the fuel cells. Therefore, MF Hydra achieves zero hydrogen losses during operation. Generally, the shelf life of liquid hydrogen in a storage tank is roughly 2-3 weeks, after which the fuel will be classed as warm and difficult for refuelling. At this point hydrogen will vent off.

⁵¹ Bernd, F. et al., 'MAN LH2 Marine Power Pack', *MAN Energy Solutions*, 2022 <<https://www.man-es.com/campaigns/download-Q2-2023/Download/man-lh-sub-2-sub-marine-power-pack/5123cf76-6869-4326-aa69-0bb2ba15a6e2/MAN-LH2-Power-Pack>>.

⁵² Zohaib Ali, 'LH2 Vessel Project Tests Marine Fuel Cells Powered by Liquid Hydrogen', *H2 Bulletin*, October 2022 <<https://www.h2bulletin.com/lh2-vessel-project-tests-marine-fuel-cells-powered-by-liquid-hydrogen/>>.

⁵³ Flynn, T., *Cryogenic Engineering, Revised and Expanded*, 2nd edn (Boca Raton: CRC Press, 2004) <<https://doi.org/https://doi.org/10.1201/9780203026991>>.

⁵⁴ Kawasaki Heavy Industries Ltd., 'Special Issue on Hydrogen Supply Chain', *Kawasaki Technical Review*, 182 (2021) <https://www.kawasaki-gasturbine.de/files/KAWASAKI_TECHNICAL_REVIEW_No_182.pdf>.

⁵⁵ Lloyd's Register Group Services Limited., 'World First for Liquid Hydrogen Transportation.', *Insights*, October 2020 <<https://www.lr.org/en/insights/articles/world-first-for-liquid-hydrogen-transportation/>> [accessed 12 May 2023].

The liquid fuel is boiled off to its gaseous form for use in a fuel cell. This is done using a vaporiser, similarly to LNG fuel. To provide hydrogen at the right pressure, pressure can be controlled inside the tank or a pump used.

A number of manufacturers have commercially available liquid hydrogen tanks. Linde has installed the only operational tank on a vessel, which is 80 m³ in volume, carrying about 4 tonnes on the MF Hydra [Case Study 9].

2.2.2 Compressed Hydrogen

Compressed hydrogen is generally stored onboard at 350 bar or 700 bar. Compression to 350 bar requires using 6% of the hydrogen's energy content, while 700 bar requires 11%. The equipment and processes are TRL/CRL9.

Generations of tanks used for compressed hydrogen are subdivided into the following types. The more advanced the type, the lighter the tanks are in comparison to the hydrogen fill that they can hold:

- Type I: Steel/aluminium gas cylinders similar to those for any technical gas, with storage pressure 250-300 bar;
- Type II: Aluminium cylinders with filament windings as reinforcement wrapped around them. The fibres can be made of glass, carbon or aramid. Storage pressure 250-300 bar;
- Type III: Composite tanks made of fibre-reinforced polymers with an inner metal liner. Storage pressure up to 700 bar;
- Type IV: Composite tanks made of fibre-reinforced polymers with an inner polymer liner (HDPE or similar). Storage pressure up to 700 bar.

Example details and specification data for Type IV marine compressed hydrogen tanks are given in Case Study 18.

Compressed hydrogen storage for maritime use is generally based on land-based hydrogen mobility applications, where hydrogen is stored in the vehicle at pressures of 700 bar for cars, and 350 bar for buses, trains, and other large vehicles. At present, there is no standard hydrogen storage pressure for maritime applications. Storage onboard is commonly either medium pressure 350 bars or high pressure at 700 bars. These are the two main storage pressures but lower pressure such as 200 bars has a lower compression cost. The disadvantage is the high-pressure risk and stored density at 350 bars (23.7 kg/m³) and 700 bars (38.7 kg/m³).

In the EU, the RH2INE⁵⁶ and RH2IWER³⁹ projects aim to standardise compressed hydrogen bunkering for inland vessels in the next 2-3 years. Together with DNV, RH2INE performed a gap analysis of standards and guidelines to identify legal and harmonisation gaps (source) finding, for example, that the use of fuel cells is not regulated by IMO and technical provisions for fuel cells are missing in the IGF Code.

Stacking compressed hydrogen into racks within standard containers (see Figure 18) facilitates swapping as a bunkering method, as explained further in section 2.4.2.

⁵⁶ Rhine Hydrogen Integration Network of Excellence (RH2INE), 'Towards Zero Emission Transport Corridors', 2023 <<https://www.rh2ine.eu/>>.

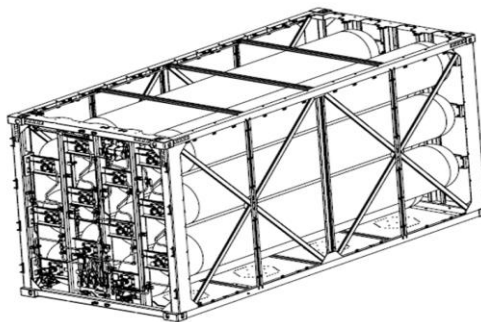

Figure 18: Containerised rack of compressed hydrogen storage tanks (Image: Hexagon Composites ASA). Metal Hydrides

Metal hydrides have been demonstrated to supply fuel cells on Type 212a submarines since the 1990s and more recently Type 214⁵⁷. In 2023, the ZEUS research ship entered service using metal hydride tanks to power a 140-kW fuel cell to supply auxiliary power. The commercial Neo Orbis vessel, commissioned by Port of Amsterdam, is under construction and will begin operating on metal hydride (sodium borohydride) fuel storage in 2024⁵⁸. These first-of-a-kind commercial vessels bring the technology to TRL/CRL9.

One type of metal hydride is sodium borohydride (NaBH_4), a granular solid hydrogen carrier to be demonstrated on the Neo Orbis vessel. Many other types exist⁵⁹. NaBH_4 releases hydrogen gas when mixed with water and a catalyst, as well as heat and a reaction by-product, sodium metaborate (NaBO_2). Theoretically, the spent reaction by-product can be reconverted back to metal hydride for reuse as fuel. This solid storage type requires less volume than storing hydrogen in compressed gaseous form⁶⁰. Bunkering operations and handling are also significantly simplified but have yet to be demonstrated on commercial vessels (TRL8).

2.3 Vessel Approval, Safety and Classification

The properties of hydrogen gas are very different from existing maritime fuels, including LNG. Compared to natural gas, hydrogen has a wider flammable range, a higher reactivity and a lower ignition energy, which may lead to a higher explosion risk if safety aspects are managed in the same way as for LNG.

Conventionally fuelled vessels are built according to prescriptive rules. When these rules are followed, the vessel can be classed and approved by the national maritime administration. However, for novel low-flashpoint fuels like hydrogen, the vessel must be built according to a number of goal-based functional rules of the IGF Part A according to the alternative design process as described in MSC.1/Circ. 1455. Furthermore, MSC.1/Circ.1647 provides interim guidelines for the safety of ships using fuel cell power installations.

Examples of important functional rules include IGF 3.2.1 with requirement for equivalent safety compared to modern conventional vessels and IGF 3.2.18 which states that no single failure in a technical system shall lead to an unsafe or unreliable situation. IGF 4.3.1-8 also contains requirements to ensure that if an explosion would still happen, the consequences shall be kept local and not lead to escalation or impairing safety functions of the vessel. Therefore, this regulatory

⁵⁷ Sünnetci, İ., 'Type 214TN REIS Class TCG PIRI REIS Submarine', *Defence Turkey*, January 2020 <<https://www.defenceturkey.com/en/content/type-214tn-reis-class-tcg-piri-reis-submarine-3827>>.

⁵⁸ The Maritime Executive, 'Port of Amsterdam Lays Keel for First "Solid Hydrogen" Fueled Vessel', *The Maritime Executive*, 23 January 2023 <<https://maritime-executive.com/article/port-of-amsterdam-lays-keel-for-first-solid-hydrogen-fueled-vessel>>.

⁵⁹ Pragma Industries, 'Hydrogen Storage', 2023 <[https://www.pragma-industries.com/hydrogen-storage/#:-:text=Metal hydride tank is a,on AB5 metal hydride alloys.>](https://www.pragma-industries.com/hydrogen-storage/#:-:text=Metal%20hydride%20tank%20is%20a,on%20AB5%20metal%20hydride%20alloys.>).

⁶⁰ te Siepe, H., 'Hydrogen in Salt as Reusable Energy, Safe Mass Storage and High Efficiency Recycling', in *ShipZERO26* (Glasgow: ZESTAs, 2021) <<https://zestas.org/shipzero-26-5/speakers/#hans>> [accessed 10 March 2023].

framework provides a solid basis for current implementation of novel hydrogen propulsion systems, whilst further prescriptive rules are developed for accelerated adoption.

For approval of a hydrogen-fuelled vessel the design team must optimise the vessel not only to fulfil its planned function in the best possible way, but also to fulfil quantitative risk criteria as well as compliance with the IGF part A functional rules to the satisfaction of Class and Administration.

It is common practice in the development of hydrogen-propelled vessels that the class approval process is split into two phases. Phase one of the design process closely involves Class and Administration, leading to preliminary approval from both. In phase two a regular construction process follows, through which the vessel is built in line with the conditions stated in the preliminary approvals.

For hydrogen vessel projects, the alternative design process can be challenging compared to traditional design by prescriptive rules. Nevertheless, expertise within hydrogen safety is available in and outside the maritime sector. Classification societies are also gaining experience and expertise. As a result, vessel designs are not only optimised for function and fuel efficiency but also for safety. Design choices are justified by risk assessments and often "*as low as reasonably practicable*" (ALARP) considerations. For many projects the minimum operational costs and best possible fuel economy are critical for realisation. Benefits of the freedom offered by the alternative design to optimise the vessel may be higher than the possible disadvantages related to a more challenging approval process.

Today, all major class societies are involved in hydrogen vessel projects and are developing class rules, with the ambition to develop safe hydrogen vessels. In November 2023, Bureau Veritas published classification Rules for hydrogen-fuelled and hydrogen-prepared ships (NR678)⁶¹.

Approval processes have been challenging but are becoming simpler with increasing experience. For example, class approval of Nedstack's hydrogen fuel cell system on the inland H2 Barge 1 took 4 years but their next project on Medusa 2 only 6 months to be approved⁶².

In summary, vessels propelled by commercially available LT-PEM fuel cells are operational today using a range of hydrogen storage options. More vessels will begin operations shortly and others have received preliminary approvals and are being constructed. Approval processes have been challenging for front-runners but are shown to be simplifying with increasing experience.

2.4 Hydrogen Bunkering

Hydrogen transfer from ship to shore can be conducted using a pipe/hose for liquid or compressed hydrogen. Liquid hydrogen has a much faster demonstrated rate of transfer (about 3,000 kg/hour) than compressed hydrogen (220 kg/hour). For this reason, compressed hydrogen refuelling is sometimes employed by swapping individual tanks or containers containing multiple tanks in order to speed up bunkering times.

Hydrogen bunkering locations are limited and mostly in Northern Europe (see Figure 19). Most consist of compressed hydrogen filling stations of varying pressure, usually 300 or 700 bar, identical to those used in road transport. Liquid hydrogen transfer to a ship is currently available in three locations. The facilities in Kobe, Japan and Hastings, Australia are fixed infrastructure including storage tanks while the bunkering system in use for the MF Hydra in Hjelmeland, Norway is a mobile system designed for use on any quayside and uses liquid hydrogen delivered by truck.

⁶¹ Bureau Veritas, 'NR678 hydrogen-fuelled ships' <https://marine-offshore.bureauveritas.com/nr678-hydrogen-fuelled-ships> [accessed 10 December 2023].

⁶² Bruinsma, J., 'Hydrogen Fuel Cell Retrofit' in *ShipZERO28* (London: ZESTAs, 2023) <https://zestas.org/shipzero28/presentations-gallery/#18> [accessed 12 December 2023].

Another mobile liquid hydrogen refueler is planned for Aberdeen as part of the HI-FIVED project⁶³. Details of various hydrogen bunkering systems are given in Case Study 19.

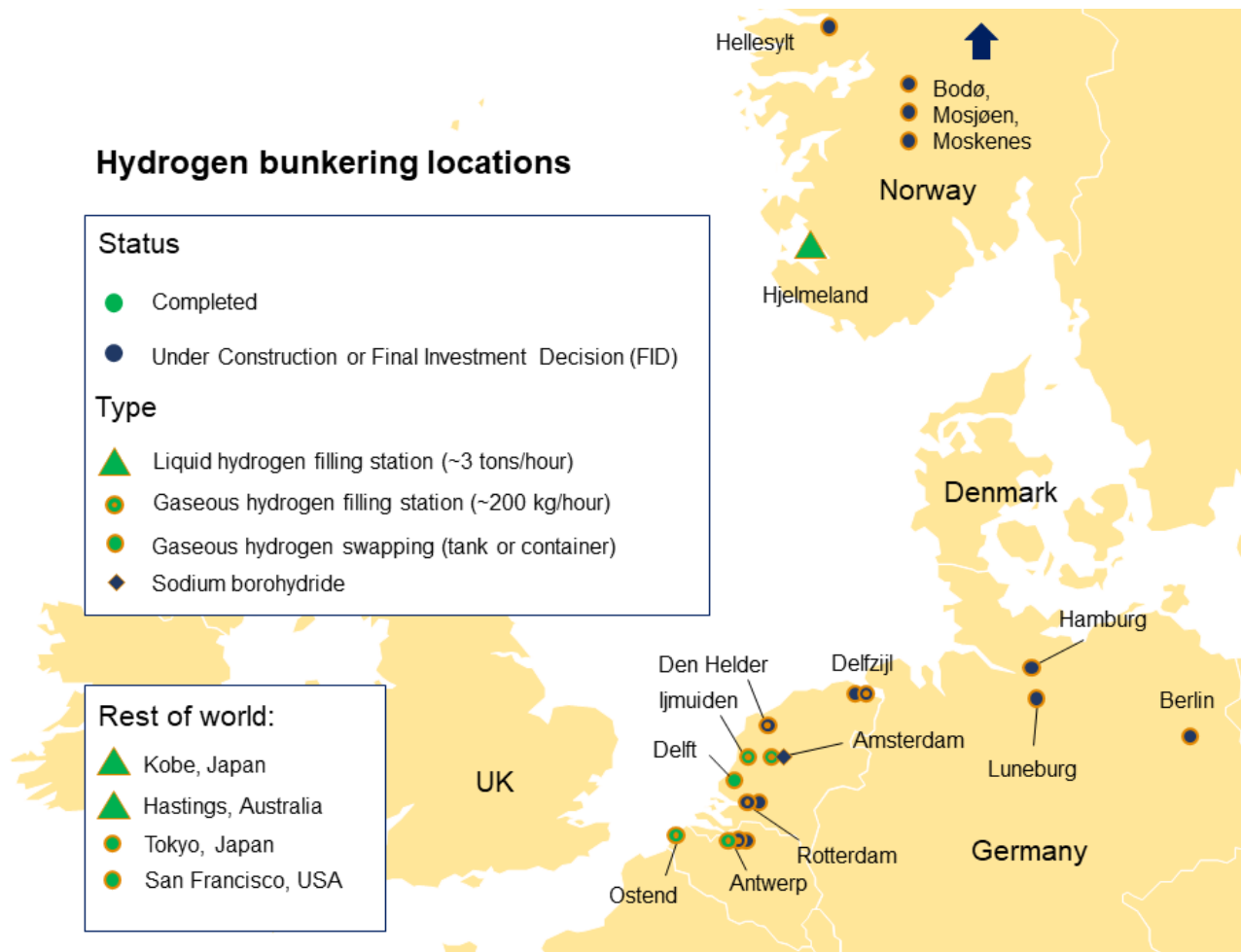

Figure 19: Map of hydrogen bunkering locations globally in April 2023 (author's own work).

2.4.1 Liquid Hydrogen

Liquid hydrogen bunkering is TRL/CRL9, being commercially operational to refuel the Hydra passenger ferry in Hjelmeland, Norway. Fixed systems are TRL8, having demonstrated shore-to-ship transfer in Kobe, Japan⁶⁴ and Hastings, Australia⁶⁵.

Mobile systems have been deployed to overcome bottlenecks in large-scale liquid hydrogen supply and infrastructure by being lightweight standalone systems which use hydrogen delivered by truck. This ensures that bunkering can be performed with no fixed quayside infrastructure or nearby fuel supply. Suppliers of such systems include Norled AS and Unitrove.

The liquid hydrogen bunkering system designed and operated by Norled AS for MF Hydra passenger ferry supplies liquid hydrogen directly to the ship (see Figure 20 and Case Study 19). While the “bunkering tower” is mobile, it can also be a fixed port structure if space on the quay is available. Boil-off losses have been minimised to pressure release from bunkering tower and truck, approximately 10-15 kg out of a liquid hydrogen load of 3.2-3.5 tonnes per truck (0.31-0.43%). For the next iterations of the system, Norled aims to collect the gas and use it locally, as is the case on

⁶³ Information from Unitrove.

⁶⁴ HyStra, 'World's First Marine Loading Arm with Swivel Joints for Liquefied Hydrogen Successfully Demonstrated Ship-to-Shore Transfer', *News Archives*, 2023 <<https://www.hystra.or.jp/en/gallery/article.html>> [accessed 12 May 2023].

⁶⁵ HESC, 'Port of Hastings', *Supply Chain*, 2023 <<https://www.hydrogenenergysupplychain.com/supply-chain/port-of-hastings/>> [accessed 12 May 2023].

board. With a loading rate of 3 tonnes/hour, it takes about 1-1.5 hours to bunker the MF Hydra's 4 tonne storage capacity.



Figure 20: Mobile liquid hydrogen bunkering tower designed and owned by Norled attached to a tube trailer, bunkering the Hydra passenger ferry. Image: Norled AS.

Liquid hydrogen bunkering can either be carried out using pressure difference or pumps. Systems using pressure difference (such as Norled's system) are designed to deliver gaseous fuel to the consumer using compression created by differentiation of temperature between liquid hydrogen and compressed hydrogen (see Figure 21). As the hydrogen warms, it evaporates to create pressure which is used to create ideal pressure for the consumer. Any excess pressure is fed back to continue feeding to the consumer.

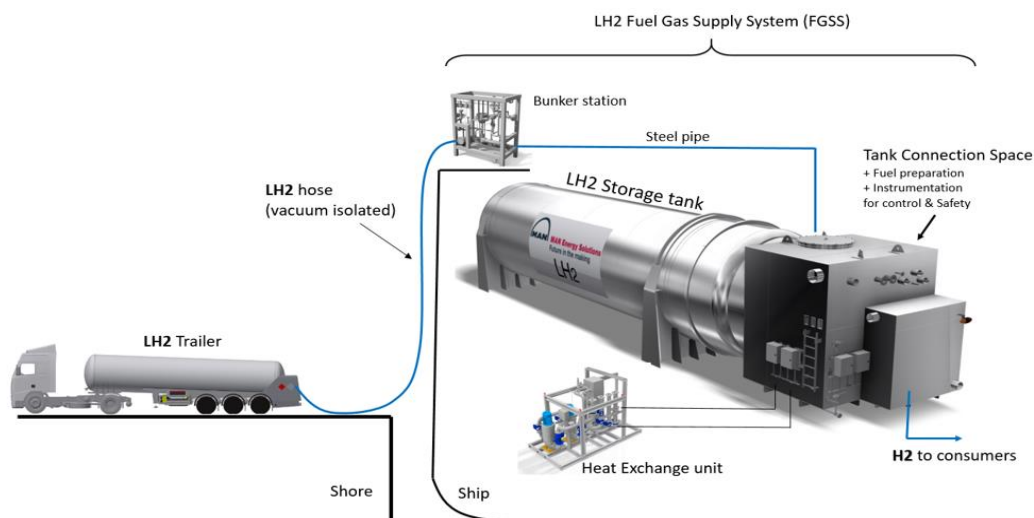

Figure 21: Diagram of typical liquid hydrogen bunkering system delivering directly to onboard storage, similar to the system designed and operated by Norled AS for MF Hydra⁴⁷.

Systems using pumps (such as Unitrove's system) have been established for decades. Hydrogen pumps are commercially available and under manufacturers' guidelines, such as Linde, Air Products and Air Liquide. Table 6 compares two liquid hydrogen bunkering systems.

Table 6: Comparison of liquid hydrogen bunkering systems.

Comparison of liquid hydrogen bunkering systems		
Supplier	Norled AS	Unitrove Innovation
TRL/CRL	TRL/CRL9	TRL5
Loading rate	3 tonnes/hour	2.1 tonnes/hour or 15,000 L/hour minimum
Dimensions (w*l*h)	5 * 4 * 12 m	1 * 1.8 * 2.5 m
Weight	15 tonnes	1 - 1.5 tonnes
Details	No pumps or power utilised. Overpressure in road trailer used to push liquid hydrogen over to ship.	4-stage pump driven by 6.5 kW motor.

Fixed bunkering systems are more permanent structures with associated storage tanks, such as the liquid hydrogen terminal at Port of Kobe, Japan⁶⁴ (see Figure 22). This consists of a Rigid Type Loading Arm System (LAS) for ship-to-shore (and vice versa) transfer. Successful liquefied hydrogen cargo handling was conducted in March 2023 and the technology is thus at TRL/CRL9 as of writing.



Figure 22: A ship-to-shore rigid Loading Arm System (LAS) installed in the hydrogen terminal at Port of Kobe, Japan. Credit: HySTRA.

For liquid hydrogen, there is no standard at present to cover marine bunkering. It was proposed that liquid hydrogen bunkering will, to a certain extent, be guided by LNG bunkering since this is well-established. ISO TC197 is responsible for implementing standards for hydrogen services.

Currently all cryogenic bunkering is based on LNG bunkering practices until such time as ISO or CEN standards are in place. ISO and CEN are working on liquid hydrogen standards which will be based on accepted LNG bunkering practices. For example, Unitrove Innovation's liquid hydrogen bunkering facility is based on recognised codes such as NFPA2, BGCA, EIGA and other standards like BS EN 10079 for explosive environment, meeting COMAH, DSEARs etc. and ensuring compliance with HSE requirements. All equipment such as high-pressure pumps, sensors, metering all comply with the above.

ISO and CEN have used LNG as a basis to facilitate standards for maritime bunkering of liquid hydrogen. NFPA2 "Hydrogen Technologies" used other NFPA codes such as NFPA 52 "Vehicular Natural Gas Fuel Systems Code" and NFPA 55 "Compressed Gases and Cryogenic Fluids Code". Unfortunately, NFPA is generic and not specific to marine.

2.4.2 Compressed hydrogen

Compressed hydrogen filling stations for ships were first demonstrated in 2008⁶⁶ and are in operation in several locations, as shown in Figure 19. These filling stations are in effect identical to those for road transport, which are widespread globally. For example, in Antwerp, Belgium a compressed hydrogen multi-modal refuelling station operated by CMB.Tech offers two hydrogen bunkering pressures for vessels at 200 and 350 bar and a tube trailer filling station at 500 bar. Two hydrogen refuelling trailers are also deployed, each capable of refuelling to 200 and 350 bar storage from 950 kg of hydrogen storage at 500 bar.

Technology has transferred from the road transport sector and follows land-based standards. Existing compressed hydrogen refuelling stations have relatively low flow rates (220 kg/h) compared to liquid hydrogen bunkering and follow SAE J2601_202005 standard for land vehicle refuelling.

A significant technical drawback of direct filling compressed hydrogen is the maximum demonstrated flow rate of about 220 kg/hour. Work is ongoing to increase this rate but rates up to 1,000 kg/hour or more are in development, at TRL5-6.

Swapping pre-filled containerised compressed hydrogen (usually in a 20' or 40' ISO frame, also called multiple-element gas containers, or MEGC) with empty ones offers reduced bunker times⁴¹ as well as offering greater flexibility and infrastructure simplicity because the associated storage and container filling can be located away from the bunkering location, for example at a road transport refuelling station or directly at the production⁵¹. This method has been adopted for commercial operations by Argo-Anleg GmbH for the inland push-boat Elektra⁴⁷ (see Case Study 20) and by Air Liquide for the inland container vessel H2 Barge 1 (see Case Study 9). Similar systems are expected on Antonie³⁷, FPS Waal, and the RH2IWER project (6 inland vessels)³⁹. For the Elektra ship, the container systems are swapped with an on-board crane. Currently, the standard for off-loading containers is ISO 10855⁵¹.

In Norway there are investments in mass produced containerised hydrogen for ship refuelling and trade. Planning consent has been awarded to a site in Mosjøen for 18,250 tonnes/year production with a 100 MW electrolyser and "filling, storing, and handling of a large number of hydrogen containers as well as a quay for seaborne transport of containers to markets in Norway and

⁶⁶ ZemShips, 'A New Development: The Hydrogen Fuelling Station', *Technology*, 2008 <<https://web.archive.org/web/20081011063719/http://www.zemships.eu/en/technology/hydrogen-fuelling-station/index.php>> [accessed 12 May 2023].

Europe⁶⁷. In Bodø, there is an FID for 5 tonnes/day bunker fuel and a yearly capacity of 1,875 tonnes of hydrogen.

There is no standard for the bunkering of compressed hydrogen for marine use, though numerous facilities exist. At a small scale, current compressed hydrogen bunkering, for example the CMB.Tech compressed hydrogen refuelling facility in Antwerp, is based on the land-based fuelling station standard i.e. ISO 19880-1 Gaseous hydrogen fuelling stations. This standard covers the design, installation, commissioning, operation, inspections and maintenance. Further relevant standards are listed in Table 7.

Table 7: List of standards relevant to hydrogen bunkering systems

Standard code	Description
ISO TS 16901:2022	Guidance on performing safety and risk assessment in the design of onshore LNG installation including ship/shore interface. This is the most likely standard to be eventually formulated for compressed hydrogen and liquid hydrogen.
NFPA 2	Hydrogen Technologies Code, is based on other NFPA codes for LNG/CNG.
ISO TS 18683	Guidelines for safety and risk assessment of LNG fuel bunkering operations
ISO BS EN 20519	Ship and Marine Technology - Specification for bunkering of liquefied natural gas fuelled vessels. Sets out the requirements for LNG bunkering transfer systems and equipment used to bunker LNG fuelled vessels.
ISO 13984	Liquid hydrogen- Land vehicle fuelling. This falls under TC197 WG 35 covering liquid hydrogen vehicle fuelling connector rated for 400 kg/hr at 1.6MPa (16 bars). The fuelling connector "could" be applied to marine applications, according to the committee meeting. The development of such a standard is ongoing. The main challenge is the requirement for "heat leak" into the connector, though several OEMs such as Rego, WEH, MannTek, are undertaking a full design.
ISO TR 15916	Covers basic considerations for the safety of the hydrogen system.
ISO TR 17177	Provides guidance for the installations, equipment and operations at the ship to terminal and ship to ship interface for hybrid floating and fixed LNG terminals. Compliance with IMO IGF practices is required. Due to the very low temperature of liquid hydrogen at 20°K (-253°C) all piping and hoses are vacuum insulated. Piping is in austenitic stainless steel and hoses are either convoluted flexible hose or composite hose.

⁶⁷ Čučuk, A., 'Zoning Plan for Gen2 Energy's Hydrogen Facility in Mosjøen Gets Approved', *Offshore Energy*, 30 March 2023 <<https://www.offshore-energy.biz/zoning-plan-for-gen2-energys-hydrogen-facility-in-mosjoen-gets-approved/>> [accessed 12 May 2023].

3.0 Green Hydrogen Production & Infrastructure

Table 8: Summary of Technology Readiness Levels (TRLs) and Commercial Readiness Levels (CRLs) of technologies for green hydrogen production and infrastructure

Technology	TRL/CRL
Green hydrogen production	
Alkaline electrolyzers (AE)	CRL10
Proton Exchange Membrane (PEM) electrolyzers	CRL10
Offshore green hydrogen production using wind power	TRL/CRL9 up to 1 MW
Offshore green hydrogen production using wave power	Expected TRL/CRL9 in 2024
Large-scale storage	
Liquid hydrogen tanks	TRL/CRL9 up to 336 tonnes, CRL10 at smaller capacities
Liquefaction	CRL10, up to 90 tonnes/day
Compressed gaseous salt cavern storage	TRL/CRL9, up to 1.5 million tonnes
Transport	
Pipelines (compressed hydrogen)	CRL11
Liquid hydrogen carriage by sea	TRL/CRL9, up to 90 tonnes
Road transport (liquid hydrogen)	CRL10
Road transport (compressed hydrogen)	CRL10
Liquid hydrogen terminal	TRL/CRL9

3.1 Production

Hydrogen is currently produced, transported and used in great quantities across the world. Global hydrogen demand was 94 million tonnes/year in 2021, almost all for industrial uses⁶⁸. However, the existing hydrogen industry is extremely polluting, with 95% of hydrogen produced using carbon-intensive steam methane reforming (SMR) from natural gas, known as 'grey hydrogen', resulting in CO₂ emissions of between 70 and 100 million tonnes annually according to the European

⁶⁸ IEA, Global Hydrogen Review 2023 (Paris, 2023) <<https://www.iea.org/energy-system/low-emission-fuels/electrolyzers>> [accessed 13 December 2023].

Commission. Ports (both coastal and inland) are currently the most common locations for hydrogen production⁵⁰.

Fortunately, low-carbon methods exist to produce hydrogen. Green hydrogen (or e-hydrogen) is made by electrolysis of water using electricity from renewable sources. The result is an absolute zero GHG fuel on a well-to-tank (WTT) lifecycle basis, with full well-to-wake (WTW) zero GHG emissions if LT-PEM fuel cells are used onboard³¹. Two types of electrolyzers are most predominant: Alkaline Electrolyzers (AE) and Proton Exchange Membrane (PEM) electrolyzers. Both are at CRL10.

In 2021, there was approximately 600 MW of operational electrolyser capacity⁶⁹ or roughly 90,000 tonnes of green hydrogen per year, of which 200 MW was located in China and 170 MW in Europe. An estimated 2.9 GW of capacity was operational by the end of 2023, corresponding to about 423,000 tonnes/year⁶⁸ and an almost fivefold increase in capacity in one year.

Electrolyser manufacturing capacity was estimated to be 13.9 GW/year at the end of 2023⁶⁸. Production is mostly in Europe and the remainder in the USA, China, Japan and South Korea. The most common installed electrolyser types in 2021 were alkaline electrolyzers (70%) followed by PEM electrolyzers (25%)⁵⁰.

Green hydrogen is required to eliminate GHG emissions from many heavy industries, so competition for this resource could become fierce in the coming decade. Green hydrogen is the basis of any 'e-fuel' (such as e-ammonia and e-methanol), so will have to be scaled up if any of these fuels is to come into widespread use. Production is expected to ramp up, at least in the EU, since the announcement of the FuelEU Maritime which requires for 2% of EU maritime fuel to be supplied from green hydrogen or green hydrogen-derived e-fuels by at least 2034⁷⁰. Import of hydrogen from regions with high renewable resources to demand centres is expected⁷¹.

In Norway, shipping companies are signing agreements of intent with green hydrogen producers to secure supply for future zero emission fleets⁷². Other producers are trying to circumvent the chicken-and-egg problem by supplying ship-ready hydrogen infrastructure as well as the fuel itself, for example by providing quayside compressed hydrogen in standard ISO containers^{50,73} (see Case Studies 19 & 20).

Offshore production of hydrogen was demonstrated in 2023 by French green hydrogen project developer Lhyfe with a 1 MW electrolyser on a floating buoy connected to an offshore wind farm off the coast of France⁷⁴. The technology is thus at CRL/TRL9. Lhyfe plan to scale up their technology with the 10 MW HOPE Project, currently in Front End Engineering and Design (FEED) stage⁷⁴. A similar project at 2.5 MW capacity is in FID stage, signed by electrolyser supplier Elogen and CrossWind and expected to be operational of the Dutch coast in 2025⁷⁵. American Bureau of Shipping (ABS) issued Approval in Principle to the Korea Research Institute of Ships & Ocean Engineering (KRISO) for an offshore green hydrogen production plant⁷⁶. KRISO are also expecting

⁶⁹ Odenweller, A. et al., 'Probabilistic Feasibility Space of Scaling up Green Hydrogen Supply', *Nature Energy*, 7.9 (2022), 854–65 <<https://doi.org/10.1038/s41560-022-01097-4>>.

⁷⁰ European Federation for Transport and Environment AISBL, 'EU Agrees to the World's First Green Shipping Fuel Requirement', *Transport & Environment* (Brussels, 23 March 2023) <<https://www.transportenvironment.org/discover/eu-confirms-the-worlds-first-green-shipping-fuel-requirement/>> [accessed 12 May 2023].

⁷¹ McKinsey & Company, *Global Hydrogen Flows, 2022* <www.hydrogencouncil.com> [accessed 12 May 2023].

⁷² Čučuk, A., 'Everfuel and Greenstat Enter Lease Agreement with Elkem for Hydrogen Hub Agder', *Offshore Energy*, 3 March 2023 <<https://www.offshore-energy.biz/everfuel-and-greenstat-enter-lease-agreement-with-elmek-for-hydrogen-hub-agder/>> [accessed 12 May 2023].

⁷³ Innovation Norway, 'Maritime Sector on the Verge of Hydrogen Transformation', *Business Norway*, 2023 <<https://businessnorway.com/articles/maritime-sector-on-the-verge-of-hydrogen-transformation>> [accessed 12 May 2023].

⁷⁴ Sinclair, S., 'Static Offshore Hydrogen Production' in ShipZERO28 (London: ZESTAs, 2023) <https://zestas.org/shipzero28/presentations-gallery/#5> [accessed 12 December 2023].

⁷⁵ HTW Editorial Team, 'Elogen to supply electrolyser for Hollandse Kust Noord offshore wind project' *KCI Media Group B.V.*, 4 July 2023 <<https://hydrogentechworld.com/elogen-to-supply-electrolyser-for-hollandse-kust-noord-offshore-wind-project>> [accessed 12 December 2023].

⁷⁶ gCaptain, 'ABS Issues AIP for an Offshore Hydrogen/Ammonia Production Platform from KRISO', *gCaptain*, 20 September 2023 <<https://gcaptain.com/abs-issues-aip-for-an-offshore-hydrogen-ammonia-production-platform-from-kriso/#:~:text=An%20offshore%20hydrogen%20and%20ammonia,generated%20by%20a%20wind%20farm.>>> [accessed 12 December 2023].

to produce green hydrogen offshore using wave power and 0.5 MW electrolysis near Jeju Island, South Korea⁷⁷. The floating buoy is currently under construction and is expected to become operational in 2024, taking offshore hydrogen production from wave power to CRL/TRL9.

3.2 Large-Scale Storage

Hydrogen is commonly stored at large scale in insulated cryogenic liquid hydrogen tanks at -253°C and 5 bar pressure (TRL/CRL9) or in underground salt caverns compressed at 150 to 200 bar (TRL/CRL9).

The world's largest liquid hydrogen tank has recently been constructed for NASA and is able to store 4,732 cubic metres or 336 tonnes of liquid hydrogen, enough to refill the Hydra ferry 84 times, corresponding to almost 5 years of operations. Advances in technology have considerably reduced boil-off from liquid hydrogen storage tanks. NASA's 336-tonne tank has a boil-off rate of 0.03% per day⁷⁸. Table 9 lists the four largest liquid hydrogen tanks in operation as of March 2023.

Table 9: Largest liquid hydrogen tanks globally. References to Case Studies (CS) in the Appendix are given where appropriate.

Tank location	Manufacturer	Volume (m ³)	Capacity (tonnes)	Purpose
Kennedy Space Centre, USA	CB&I	4,732 ⁷⁹	336	Rocket fuel
Kennedy Space Centre, USA	CB&I	3,800 ⁸⁰	270	Rocket fuel
Port of Kobe, Japan	Kawasaki Heavy Industries	2,500 ⁸¹	178	Import terminal
Tanegashima Space Center, Japan	Kawasaki Heavy Industries	540 [CS21]	38	Rocket fuel

The 178-tonne liquid hydrogen tank at Port of Kobe, Japan stores hydrogen for transfer to the liquid hydrogen carrier Suiso Frontier, detailed in Sections 3.3 and 3.4. A photograph of the storage tank is given in Figure 23.

⁷⁷ Garanovic, A., 'Wave energy plant in South Korea to produce green hydrogen', *Navingo*, 6 June 2023 <<https://www.offshore-energy.biz/wave-energy-plant-in-south-korea-to-produce-green-hydrogen/>> [accessed 12 December 2023].

⁷⁸ A. M. Swanger, 'Final Test Results for the Ground Operations Demonstration Unit for Liquid Hydrogen', *Cryogenics Society of America, Inc.*, 6 May 2023 <<https://doi.org/10.1016/J.CRYOGENICS.2017.10.008>> [accessed 12 May 2023].

⁷⁹ Fesmire, J. E., and Swanger, A., 'Overview of the New LH 2 Sphere at NASA Kennedy Space Center', in *DOE/NASA Advances in Liquid Hydrogen Storage Workshop* (NASA Kennedy Space Center, FL: US Department of Energy, 2021).

⁸⁰ NCE Maritime CleanTech, *Norwegian Future Value Chains for Liquid Hydrogen*, 2016 <<https://maritimecleantech.no/wp-content/uploads/2016/11/Report-liquid-hydrogen.pdf>> [accessed 12 May 2023].

⁸¹ Kawasaki Heavy Industries Ltd., *Development of Liquefied Hydrogen Terminal*, 2021 <<https://global.kawasaki.com/en/corp/rd/magazine/182/pdf/n182en06.pdf>> [accessed 12 May 2023].



Figure 23: The world's third largest liquid hydrogen tank forms part of an import terminal at Port of Kobe, Japan and can store 178 tonnes⁸¹ (image: HyTouch Kobe).

Naturally, storage of liquid hydrogen requires liquefaction. Liquefaction plants are in commercial operation around the world, mostly to supply space rockets and heavy mobility. As examples, Air Liquide operates a 90 tonnes/day plant in South Korea⁸² and a 30 tonnes/day plant⁸³, each for the mobility sector. Linde Kryotechnik has deployed liquefiers up to 34 tonnes/day capacity⁸⁴, Plug Power up to 30 tonnes/day⁸⁵, Kawasaki Heavy Industries up to 25 tonnes/day with non-stop operation of 3,000 hours demonstrated⁵⁴ and Chart Industries supplies off-the-shelf liquefaction plants up to 30 tonnes/day capacity with a lead time of about 12 months⁸⁶. In addition, suppliers such as Frabrum, Absolute Hydrogen, Hylum, GenH2 and Linde offer liquefaction at smaller capacities (100s of kg/day) for low-scale usage. Liquefaction is thus at CRL10 at both small and larger scales.

Compressed hydrogen can be stored in large quantities using underground salt caverns. These are artificially created by injecting water into geological salt deposits and removing the dissolved brine mixture. The result is a large, tight cavity in the rock where pressurised hydrogen can be stored, usually at 150 to 200 bar⁸⁷. Four underground hydrogen storage caverns are in commercial operation globally as of March 2023, most notably in the US Gulf Coast where a storage cavern of up to 130 million m³ capacity, or 1.5 million tonnes at 150 bar, is operated by Air Liquide⁸⁸. This technology is thus at TRL/CRL9.

3.3 Transport

Pipelines transporting compressed gaseous hydrogen are conventional technology used on land for heavy industries. About 4,500 km of hydrogen pipelines are currently in operation around the world⁵⁰. Pipelines enable carriage of pure hydrogen over long distances using similar infrastructure to natural gas pipelines.

⁸² Air Liquide, 'Air Liquide Hydrogen Activities Are Accelerating in South Korea as Demand Is Growing Fast', *Press Releases* (Paris, July 2021) <<https://www.airliquide.com/group/press-releases-news/2021-07-27/air-liquide-hydrogen-activities-are-accelerating-south-korea-demand-growing-fast>> [accessed 12 May 2023].

⁸³ Farges, O., 'State-of-the-Art of Hydrogen Liquefaction', in *DOE Workshop* (Houston, TX: US Department of Energy, 2022) <[https://www.energy.gov/sites/default/files/2022-03/Liquid H2 Workshop-Air Liquide.pdf](https://www.energy.gov/sites/default/files/2022-03/Liquid%20H2%20Workshop-Air%20Liquide.pdf)> [accessed 12 May 2023].

⁸⁴ Linde Engineering, 'Hydrogen Liquefiers', *Cryogenic Plants*, 2023 <https://www.linde-engineering.com/en/process-plants/cryogenic_plants/hydrogen_liquefiers/index.html> [accessed 12 May 2023].

⁸⁵ Plug Power, 'Hydrogen Liquefiers', *Hydrogen*, 2023 <<https://www.plugpower.com/hydrogen/hydrogen-liquefier/>> [accessed 12 May 2023].

⁸⁶ Langeteig, E., 'Hydrogen Supply Chain Infrastructure, A-Z' in *ShipZERO28* (London: ZESTAs, 2023) <https://zestas.org/shipzero28/presentations-gallery/#6> [accessed 12 December 2023].

⁸⁷ NEUMAN & ESSER GROUP, 'Hydrogen Storage in Salt Caverns', 2023 <<https://www.neuman-esser.de/en/company/media/blog/hydrogen-storage-in-salt-caverns/>> [accessed 12 May 2023].

⁸⁸ Air Liquide USA, 'H2 Storage & Power | Air Liquide USA', 2023 <<https://usa.airliquide.com/sustainability/hydrogen/h2-storage-power#9896>> [accessed 12 May 2023].

Waterborne carriage of liquid hydrogen has been in use since at least 1977 at NASA's Stennis Space Centre in Mississippi (see Figure 24). On at least one occasion, a fully loaded NASA liquid hydrogen barge was towed across the Caribbean Sea from the US Gulf Coast to the European Space Agency rocket launch facility in French Guyana⁵³.



Figure 24: Liquid hydrogen barges berthed at Stennis Space Center in 1977. Image: NASA/Stennis.

Since 2021, bulk liquid hydrogen carriage by sea has been demonstrated on the carrier *Suiso Frontier* (see Figure 25), which has a capacity of 90 tonnes liquid hydrogen in a 1,250 m³ double-shielded and double-insulated cryogenic tank⁵⁴.

The maiden Japan-Australia voyage of the *Suiso Frontier* resulted in zero boil-off gas due to extensive boil-off management. Boil-off is managed with a cylindrical pressure accumulator storage tank which allows the inner pressure to increase while storing boil-off gas internally, like an LNG carrier⁵⁴. Hydrogen boil-off gas could be used as main engine fuel, as with LNG carriers but this is not employed on the *Suiso Frontier*. Utilising boil-off gas for ship propulsion has been demonstrated on passenger ferry *MF Hydra* (see section 2.2.1 and Case Study 31) but has yet to be demonstrated on a carrier.

Bulk carriage of compressed hydrogen is expected to be demonstrated by 2024 as part of the HyEkoTank project which will retrofit an 18,600-dwt product tanker with 4,000 kg of compressed hydrogen storage³⁸. The vessel will also be fitted with a 2.4 MW fuel cell system for auxiliary power (see Table 4).

Road transport of liquid hydrogen has been in operation since the 1950s and is now at CRL10⁸⁹. A number of companies including Linde Gas, Kawasaki Heavy Industries [Case Study 21] and Hylium offer liquid hydrogen transport by truck carrying between 2.5 and 3.5 tonnes in ISO 40-foot container-sized tube trailers with vacuum lamination and thermal insulation.

⁸⁹ Sloop, J., 'LIQUID HYDROGEN AS A PROPULSION FUEL, 1945-1959' (NASA SP-4404, 1978) <<https://history.nasa.gov/SP-4404/ch8-11.htm>> [accessed 12 May 2023].



Figure 25: The world's first liquid hydrogen carrier Suiso Frontier berthed at a hydrogen terminal in Port of Kobe, Japan. Image: HySTRA.

A long-distance supply chain by road for liquid hydrogen has been established for refuelling the Hydra passenger ferry in Hjelmeland, Norway [Case Study 19]. Green hydrogen is transported over 1,000 km from a 24-MW electrolyser in Leuna, Germany, by truck.

Compressed hydrogen transport by road is also CRL10 and offered at high purity and at a range of pressures by a number of companies including NPROXX, Air Liquide, BayoTech and Linde Gas. Providers supply tanks of compressed hydrogen in standard 20- or 40-foot ISO containers up to 1,100 kg per trailer⁹⁰.

3.4 Liquid Hydrogen Terminals

The liquefied hydrogen terminal at Port of Kobe, Japan, consists of a liquid hydrogen storage tank, a loading arm system to load/unload liquefied hydrogen between a carrier and the shore, and facilities for handling boil-off gas, including a compressor for hydrogen gas that evaporates from the tank and a boil-off gas holder and a vent stack to release hydrogen gas that is generated while liquefied hydrogen is being loaded or unloaded⁸¹.

The corresponding terminal at Port of Hastings, Australia, consists of a similar loading and unloading ship-to-shore fixed transfer system, a liquefaction plant of 0.25 tonnes/day capacity and a 41-m³ liquid hydrogen storage container.

International standards for a liquefied hydrogen terminal have yet to be defined. Currently, the only international standards for low temperature ship-to-shore transfer are those that the International Organization for Standardization (ISO) set for LNG, but they have yet to be established for liquid hydrogen⁸¹. Kawasaki Heavy Industries has set up an ISO committee for the standardisation of liquefied hydrogen equipment.

⁹⁰ Zorn, T., *Innovation & Experience. Hydrogen Technology and Infrastructure*, 2013 <<https://energiforskmedia.blob.core.windows.net/media/18546/aga-linde-h2-dec.pdf>>.

The Suiso Frontier is currently demonstrating a transoceanic supply chain by transporting cargo between Japan and Australia. This is an important milestone as trade has the opportunity to reduce the price of hydrogen by 25%⁷¹ by connecting large renewable sources with demand centres.

4.0 Wind Propulsion

Wind propulsion technologies have been described in detail in a number of documents submitted to the IMO, such as MEPC 79/INF.21 and MEPC80/INF.33. Such technologies are absolute zero GHG as they harness only renewable wind for free and directly, allowing fuel consumption and therefore GHG emissions to be reduced overall on the ship. Verified reductions in GHG emissions have shown to be 5-20% on retrofit installations, depending on route and vessel. Larger reductions are expected with newbuilds and additional measures such as voyage optimisation and weather routing.



Figure 26: Example of folding rotor sail foundation including the tilting system cylinder. Image: Dealfeng New Energy Technology Ltd.).

According to the International Windship Association (IWSA), there were 22 large vessels with wind propulsion technology installed as of December 2022, in addition to numerous sail cargo vessels and traditional sail powered ships in developing countries. By December 2023, the number of installations on large ocean-going vessels was 31, corresponding to 2 million deadweight tonnes⁹¹. Furthermore, there were 8 wind-ready ships in operation, 22 ships with wind propulsion technology installations pending, and 5 newbuild ships on order that will have primary wind propulsion technology installed.

Wind propulsion has been installed on a diverse range of ship types: bulk carriers, tankers, RoRo, ferries, general cargo and fishing vessels, according to MEPC 79/INF.21. Types of wind propulsion technologies that have seen installation as of Q4 2022 are rotor sails, suction wings, rigid sails, kites and soft/hybrid sails.

Table 10: Installations of wind propulsion devices by type and vessels, September 2023⁹².

Type	Installations (rigs)	Installations (vessels)	Ship types
Rotor sails	44	16	Bulk, RoPax, RoRo, tanker, general cargo
Suction wings	31	16	Bulk, RoPax, RoRo, tanker, general cargo, fishing

⁹¹ Mandra, J. O., 'IWSA: More wind-powered ships than large cargo vessels running on low and zero-carbon fuels', *Navingo*, 5 December 2023 <https://www.offshore-energy.biz/iwsa-there-are-more-wind-powered-ships-than-large-cargo-ships-operating-on-low-and-zero-carbon-fuels/> [accessed 14 December 2023].

⁹² Boulland, J., 'Evolution of class notation connecting wind to the ships energy system' in ShipZERO28 (London: ZESTAs, 2023) <https://zestas.org/shipzero28/presentations-gallery/#15> [accessed 12 December 2023].

Wing sails	17	8	Bulk, RoPax, RoRo, tanker, general cargo, yacht
Kite sails	6	6	Car carrier, general cargo

Each type can be considered as TRL/CRL9 as of December 2023. Company announcements suggest that rotor sails, kites and solid sails will achieve CRL10 in the next 1-2 years (see Case Studies 32 and 33).

Table 11: Summary of Technology Readiness Levels (TRLs) and Commercial Readiness Levels (CRLs) of wind propulsion technologies

Wind propulsion technology type	TRL/CRL 2023	TRL/CRL outlook 2024-25
Rotor sails	TRL/CRL9	CRL10
Suction wings	TRL/CRL9	CRL9
Rigid sails	TRL/CRL9	CRL10
Kites	TRL/CRL9	CRL10
Soft/hybrid sails	TRL/CRL9	CRL9

5.0 Combining Technologies to Achieve Deep Emissions Reductions and Absolute Zero

The technologies presented thus far are each absolute zero GHG emissions technologies at point of use. When used in combination, these technologies are still absolute zero at a full vessel level. However, these technologies can also reduce emissions by using them in combination with conventional technologies, for example by adding wind-assisted propulsion, battery ESS, green hydrogen as a drop-in fuel in ICE and hydrogen fuel cells as auxiliary power units or as part of a hybrid propulsion system. This is particularly advantageous for making significant GHG emissions reductions on older vessels through retrofits.

A number of vessel types in certain operating profiles have achieved absolute zero today using electric or hydrogen-electric systems as shown in Sections 1 and 2. While a number of barriers remain regarding cost and supply of zero emission fuels, these can be reduced on new builds by incorporating energy efficiency technologies, making absolute zero emissions vessels more technically and economically viable today.

In 2019, the ICCT Technical Workshop on Zero Emission Vessel Technology found that “some segments may be better suited for battery power, fuel cells, wind power, solar power, etc., or different combinations of these solutions.” and that there was a need to “identify segments of the international shipping sector that might be paired with a particular technology solution or solutions” (p11)⁹³. Since 2019 the technology, fuel infrastructure and availability has advanced considerably. Today, commercial cargo vessel designs combining zero emissions technology to achieve near zero (Egil Ulvan Rederi AS, With Orca⁹⁴) and absolute zero (Veer Corp.⁹⁵) GHG emissions have received approval in principle from class societies.

Supplementary technologies exist to further reduce onboard energy requirements. Table 12 presents commercially installed technologies that contribute significantly (at least 5% on vessels under or equal to 5,000 GT and at least 2% on vessels above 5,000 GT) to reduce overall energy requirements and GHG emissions. The technologies are listed by number of vessels with installations.

Technologies for directly harvesting renewable energy onboard also contribute to reducing power demand and thus emissions, for example, 134 kWp of installed solar panels on a 135m inland vessel, can achieve 12% fuel savings corresponding to 33,000 L/year and 107 tonnes CO₂/year avoided [Case Study 25].

⁹³ The International Council on Clean Transportation (ICCT), ‘Workshop Summary’, in *ICCT Technical Workshop on Zero Emission Vessel Technology* (San Francisco, CA: ICCT, 2019) <<https://theicct.org/events/zero-emission-vessel-workshop-SF-2019>> [accessed 12 May 2023].

⁹⁴ Egil Ulvan Rederi AS, ‘Egil Ulvan Rederi New Project “With Orca” a Hydrogen Fuelled Bulk Carrier Project Awarded LR Approval in Principle.’, *Press Release*, 2023 <<https://ulvan-rederi.no/egil-ulvan-rederi-new-project-with-orca-a-hydrogen-fuelled-bulk-carrier-project-awarded-lr-approval-in-principle/>> [accessed 12 May 2023].

⁹⁵ Southcott, D., ‘The Queen of Clean’ in *ShipZERO28* (London: ZESTAs, 2023) <<https://zestas.org/shipzero28/presentations-gallery/#3>> [accessed 14 December 2023].

Table 12: Summary of supplementary technologies to further reduce onboard energy requirements, including Technology Readiness Levels (TRLs) and Commercial Readiness Levels (CRLs)

Technology	Supplier(s)	Description	TRL/ CRL	Vessel installations	GHG emissions reductions
Energy efficiency technologies					
Air lubrication	Silverstream [CS23], Mitsubishi Heavy Industries, TMC, Marine Performance Industries, Howden, Armada Technologies	Saves energy requirements by reducing resistance on the hull with air bubbles. Retrofittable.	CRL 10	At least 57 large vessels ^{96,97,98} and at least 179 vessels on order ^{99, 100}	8-10%
Hull Vane	Hull Vane [CS24]	Wing-shaped hydrodynamic attachment which suppresses stern waves and reduces running trim, thus resistance. Retrofittable.	TRL/ CRL 9	12 (6 yachts, 3 commercial vessels, 3 naval vessels)	10-20%
Bow wind deflector	MOL, ONE, CMA CGM	Reduces wind resistance to container ships. Retrofittable.	TRL/ CRL 9	9 container ships up to ~21,700 TEU, at least 10 on order ¹⁰¹	2% ¹⁰²
Gate rudder system	GATERS Project consortium [CS34]	High-lift rudder foils on either side of the propeller reduce fuel consumption by replacing drag of a traditional rudder	TRL/ CRL 9	5 coastal vessels up to 550 GT [CS34] (2 container, 2 general	15-35% and underwater noise reduction up to 15 db

⁹⁶ MPS, 'Installation Completed', *Press Release*, 2023 <<https://www.marineperformancesystems.com/news/successful-commissioning-of-berge-toubkal/>> [accessed 12 May 2023].

⁹⁷ TMC Compressors, 'Market Leading Compressors', *Press Release*, 2023 <<https://www.tmc.com/>> [accessed 12 May 2023].

⁹⁸ Carlaw, A., 'Floating on Air – Air Lubrication' Z' in *ShipZERO28* (London: ZESTAs, 2023) <https://zestas.org/shipzero28/presentations-gallery/#23> [accessed 14 December 2023]

⁹⁹ The Maritime Executive, 'Air Lubrication Takes Off in LNG Carrier Segment' *The Maritime Executive*, 23 August 2023 <<https://maritime-executive.com/article/air-lubrication-takes-off-in-lng-carrier-segment>> [accessed 14 December 2023]

¹⁰⁰ Baker, E., 'KCC to equip next four vessels with Silverstream System air lubrication technology' *UKI Media & Events*, 24 November 2023 <https://www.electrichybridmarinetechology.com/news/power-and-propulsion/kcc-to-equip-next-four-vessels-with-silverstream-system-air-lubrication-technology.html> [accessed 14 December 2023]

¹⁰¹ Schuler, M., 'ONE Adds to Orderbook with Order for Ten Large Containership', *gCaptain*, 15 March 2023 <https://gcaptain.com/one-adds-to-orderbook-with-order-for-ten-large-containership/> [accessed 14 December 2023]

¹⁰² Ship Nerd, 'Bow Windshield, New Rising Containership Feature', *Ship Nerd*, February 2023 <<https://www.shipnerdnews.com/bow-windshield-new-containership-feature/>> [accessed 12 May 2023].

		system with a thrust-generating arrangement. Retrofittable.		cargo, 1 training ship) and 2 on order	[CS34]
Onboard renewable generation technologies					
Onboard solar panels	Wattlab [CS25], Solbian	Onboard solar panels generating renewable electricity	TRL/ CRL 9	At least 8 inland vessels	12%
Bow foils	Wavefoil	Converts wave power into thrust by generating lift greater than the drag as the vessel pitches. Retrofittable.	TRL/ CRL 9	4 vessels up to 1,260 GT	5-15% ¹⁰³

Vessel design is an important factor in efficiency. For example, a number of companies have designed zero emission small vessels with very low power requirements using innovative hydro-foiling hull designs^{104,105}.

Combining many technologies to achieve absolute zero emissions require electrification to efficiently manage different incoming and outgoing power sources. As mentioned in section 1.0, batteries and other components such as BMS and electric drives are crucial. System integrators combine these with other technologies to build zero emission vessels. Battery ESS particularly can enable the integration of alternative fuels like hydrogen in hybrid systems due to several reasons:

- Higher costs for alternative fuels increase the need for efficiency. Batteries are a proven method to increase the efficiency for most types of ships.
- Lower energy density of alternative fuels compared to diesel will require innovative ways of reducing fuel use. Besides using batteries to increase the efficiency of the vessel, batteries can also be charged in port when there is access to shore power. This energy can be used to eliminate the use of generators while in port, or even the use of fuel for part of the (in port) operations.
- Some technologies, fuel cells for example, rely on the use of batteries for handling peak power demands. Batteries are an excellent and proven technology to handle these peaks in a hybrid configuration. ICEs can benefit from the peak shaving capabilities of battery systems.

In recent years, ICCT research has demonstrated both the potential for liquid hydrogen fuel cells to replace fossil fuels for container ships on the transpacific corridor and the energy-saving and emissions-reduction potential of rotor sails. This study gives an example of three bulk carriers retrofitted with rotor sails and liquid hydrogen to achieve absolute zero GHG emissions on the vessel¹⁰⁶. When wind and electric propulsion with liquid hydrogen as a fuel are incorporated at the design stage, efficiency technologies and innovative hull forms can be factored in to drastically reduce fuel requirements, for example on Veer Corp.’s design for a wind-assisted hydrogen powered vessel⁹⁵.

¹⁰³ Wavefoil, 'Wavefoil - Retractable Bow Foils', 2022 <<https://wavefoil.com/>> [accessed 12 May 2023].
¹⁰⁴ Artemis Technologies, 'Artemis EFOILER® - Zero-Emission High-Speed Maritime Transport', 2023 <<https://www.artemistechnologies.co.uk/efoiler/#efoiler>> [accessed 12 May 2023].
¹⁰⁵ Boundary Layer Technologies, 'Introducing Valo: The World's First Hyperfoil', 2023 <<https://www.boundarylayer.tech/>> [accessed 12 May 2023].
¹⁰⁶ Bryan Comer and others, *Decarbonizing Bulk Carriers with Hydrogen Fuel Cells and Wind-Assisted Propulsion: A Modeled Case Study Analysis*, 2022 <<https://theicct.org/publication/hydrogen-and-propulsion-ships-jan22/>> [accessed 12 May 2023].

6.0 Crew Training

This section describes the current provision or development of training, linked with requirements where they exist, in three main areas of zero-emissions commercial shipping, namely electric systems, hydrogen propulsion and wind propulsion.

The IMO announced the launch of the Baseline Training Framework for Seafarers in Decarbonization at COP28 in November 2023¹⁰⁷. The training is planned to be tested in Asia through a programme led by World Maritime University (WMU) with support from the Maritime Technology Cooperation Centre (MTCC) Asia and other partners. The packages will be made available globally to all the established MTCCs and IMO Member States for potential use by maritime education and training (MET) institutes. While the training is aimed at preparing seafarers for zero or near-zero emission ships, it is not yet clear what propulsion systems and other technologies will be covered. The development of the training is expected by 2025.

6.1 Electric Systems Training

As established in section 1.1.1, electric propulsion systems may be pure electric zero-emissions systems or part of fuel-drive hybrid-electric systems. There is much pre-existing training which covers skills required in this area which can be found in mainstream International Convention on Standards of Training, Certification and Watchkeeping for Seafarers (STCW) competencies, for example: electro-technical training, electrical aspects of Engineering Certificate of Competency (CoC) and high voltage training where applicable.

However, there are additional aspects not fully covered, for example advanced battery safety and management, some power management/control systems, magnetic clutches and other drive-specific equipment to give some examples.

South Essex College, London, UK has developed a comprehensive training course for electric vessels, both deck and engineering¹⁰⁸. This includes servicing and, due to the nature of the equipment, is able to be more “hands-on” than for hydrogen systems. This course does not yet hold any flag state accreditation but they are in correspondence with classification societies.

6.2 Hydrogen Training

Hydrogen fuel is currently classed alongside other volatile fuels such as LNG and methanol, within the IGF code. This already has a training structure, however “IGF” training is usually LNG-based and lacks the scope to address specifics of hydrogen systems. Crews of hydrogen-fuelled vessels who attend LNG based IGF training will technically meet the letter of the law but will lack sufficient competence and vessel familiarisation.

The world’s first flag state (UK MCA) recognised hydrogen crew training was developed by Orkney College in Scotland, UK, and is delivered after crews have attended regular Liquid Natural Gas/Gaseous & Low-Flashpoint Fuels (LNG/IGF) training¹⁰⁹.

¹⁰⁷ International Maritime Organization (IMO), ‘Training seafarers for a decarbonized future’, *Latest news*, 6 December 2023, <https://www.imo.org/en/MediaCentre/Pages/WhatsNew-2014.aspx> [accessed 14 December 2023].

¹⁰⁸ Course contact: simon.lofting@southessex.ac.uk

¹⁰⁹ Course contact: mark.shiner@uhi.ac.uk

Over four days the course covers hydrogen safety awareness, behaviour of the gas, safety procedures, decision support systems with SMS, vessel operation, bunkering exercises and simulated firefighting. The course covers current requirements for deck and engineering departments at basic and advanced levels. At the time of writing, hydrogen propulsion installations are serviced and repaired by manufacturers, negating much engineering input from crews apart from testing and general maintenance.

A broad summary of the Orkney Hydrogen vessel course, taught over 4 days, following the crew's attendance of STCW IGF LNG Training is shown below. A full syllabus is available on request:

- Day 1. General hydrogen safety awareness, behaviour of the gas, MARPOL, First Aid, Installation overview, precautions and safety culture, hazards, PPE, storage considerations, fittings, leaks and venting.
- Day 2. Health and safety measures, ATEX [Explosive Atmospheres] - general and specific precautions, Bunkering - principles, arrangements and procedures, maintenance culture, inerting, isolations valves, inspection principles, firefighting theory.
- Day 3. Workshop day with crew and technical staff covers SMS, operational procedures, system design, decision-support, technical details, risk assessment, inspection, functional testing, fault codes and scenarios etc.
- Day 4. Bunkering training includes 2 out of 3 required bunkering iterations. Firefighting exercise and assessment of understanding.

6.3 Wind Propulsion Training

Wind propulsion lacks a clear training structure for commercial operations. Such vessels are dealt with on a case-by-case basis at flag state level and categorised on the basis of tonnage, with the sail component being seen as secondary propulsion. In the development of new wind-powered vessels, class societies are preferring to see the sail propulsion equipment as auxiliary. Some operators have expressed a wish to see a new vessel category "Sail Cargo Vessel" (SCV).

While the command of traditional large sailing craft is best suited to an apprenticeship model of training, modern systems such as rotor sails, suction wings, kites, rigid sails and soft sails will require a training timescale closer to modern powered vessels to be competitive.

Enkhuizer Zeevaartshool in the Netherlands is beginning to address this with a short course topic but the authors are not aware of a fully-fledged commercial course being available¹¹⁰. Applied University of Emden-Leer in Germany offers comprehensive training courses in ship handling simulation and CFD with the focus on wind hybrid systems, for example rotor sails or kites¹¹¹.

¹¹⁰ Enkhuizer Zeevaartschool, 'Wind Assisted Ship Propulsion', 2023 <<https://www.ezs.nl/wind-assisted-ship-propulsion.html>> [accessed 12 May 2023].

¹¹¹ Hochschule Emden/Leer, 'Laboratories', 2023 <<https://www.hs-emden-leer.de/en/current-students/faculties/maritime-sciences/research-laboratories-projects/laboratories>> [accessed 12 May 2023].

7.0 Conclusion

Absolute zero-GHG technologies are commercially available today and installed on a growing number of vessels. This paper presented fully demonstrated absolute zero GHG technologies providing main propulsion or auxiliary power onboard vessels, as well as onshore infrastructure where relevant.

Pure electric systems are common in certain ship types while hybrid-electric vessels are well-established. Hydrogen-electric propulsion using fuel cells is commercially ready at multi-MW scale.

Relevant infrastructure for charging or refuelling of absolute zero GHG technologies is also commercially ready. Where fixed charging or refuelling is unfeasible due to operational constraints, swappable batteries or fuel tanks can be deployed. In the case of hydrogen fuel, the technology required for an absolute zero GHG supply chain is in early adoption, including production, storage, and transport.

Combinations of absolute zero GHG technologies facilitate absolute zero GHG vessels. Electric systems are the foundation of absolute zero GHG vessels and are commercially ready. By integrating hybrid-electric systems with hydrogen fuel cells, wind propulsion and supplementary technologies for increased energy efficiency or onboard renewable energy generation, absolute zero GHG vessels of greater sizes and power can be achieved using demonstrated and commercialised technology.

References

- ABB, 'Azipod Electric Propulsion', ABB Marine & Ports, 2023 <<https://new.abb.com/marine/systems-and-solutions/azipod#highice>> [accessed 10 May 2023]
- , 'Largest Emission-Free Electric Ferries for ForSea', ABB Marine & Ports - Marine References, 14 November 2018 <<https://new.abb.com/marine/marine-references/forsea>> [accessed 4 December 2019]
- , 'Quantum of the Seas', ABB Marine & Ports - Marine References, 2023 <<https://new.abb.com/marine/marine-references/quantum-of-the-seas>> [accessed 10 May 2023]
- , 'In Pictures: Azipod® Propulsion Installed on Wasaline's New Ferry in Just One Week' <<https://new.abb.com/news/detail/67578/in-pictures-azipod-propulsion-installed-on-wasalines-new-ferry-in-just-one-week>> [accessed 10 May 2023]
- Air Liquide USA, 'H2 Storage & Power | Air Liquide USA', 2023 <<https://usa.airliquide.com/sustainability/hydrogen/h2-storage-power#9896>> [accessed 12 May 2023]
- , 'Air Liquide Hydrogen Activities Are Accelerating in South Korea as Demand Is Growing Fast', Press Releases (Paris, July 2021) <<https://www.airliquide.com/group/press-releases-news/2021-07-27/air-liquide-hydrogen-activities-are-accelerating-south-korea-demand-growing-fast>> [accessed 12 May 2023]
- Zohaib, A., 'LH2 Vessel Project Tests Marine Fuel Cells Powered by Liquid Hydrogen', H2 Bulletin, October 2022 <<https://www.h2bulletin.com/lh2-vessel-project-tests-marine-fuel-cells-powered-by-liquid-hydrogen/>> [accessed 12 May 2023]
- Argo-Anleg GmbH, 'Lighthouse Project: Canal Push Boat ELEKTRA', Projects, 2023 <<https://www.argo-anleg.de/en/project/kanalschubboot-elektra/>> [accessed 12 May 2023]
- Artemis Technologies, 'Artemis EFOiler® - Zero-Emission High-Speed Maritime Transport', 2023 <<https://www.artemistechnologies.co.uk/efoiler/#efoiler>> [accessed 12 May 2023]
- Baker, E., 'KCC to equip next four vessels with Silverstream System air lubrication technology' UKI Media & Events, 24 November 2023 <<https://www.electrichybridmarinetechology.com/news/power-and-propulsion/kcc-to-equip-next-four-vessels-with-silverstream-system-air-lubrication-technology.html>> [accessed 14 December 2023]
- Baker, E., 'Oasis Marine transfers power through its Oasis Power Buoy to a crew transfer vessel', UKI Media & Events, 23 November 2023 <<https://www.electrichybridmarinetechology.com/news/battery-technology/oasis-marine-transfers-power-through-its-oasis-power-buoy-to-a-crew-transfer-vessel.html>> [accessed 12 December 2023]
- Bernd, F., Estermann, L., Tolgos, S., McCarthy, A. and Makarov, S., 'MAN LH2 Marine Power Pack', MAN Energy Solutions, 2022 <<https://www.man-es.com/campaigns/download-Q2-2023/Download/man-lh-sub-2-sub-marine-power-pack/5123cf76-6869-4326-aa69-0bb2ba15a6e2/MAN-LH2-Power-Pack>> [accessed 12 May 2023]
- Boulland, J., 'Evolution of class notation connecting wind to the ships energy system' in ShipZERO28 (London: ZESTAs, 2023) <<https://zestas.org/shipzero28/presentations-gallery/#15>> [accessed 12 December 2023]
- Boundary Layer Technologies, 'Introducing Valo: The World's First Hyperfoil', 2023 <<https://www.boundarylayer.tech/>> [accessed 12 May 2023]
- Bruinsma, J., 'Hydrogen Fuel Cell Retrofit' in ShipZERO28 (London: ZESTAs, 2023) <<https://zestas.org/shipzero28/presentations-gallery/#18>> [accessed 12 December 2023]
- Buljan, A., 'Damen Launches World's First Fully Electric SOV Capable of Charging Offshore at OEEC 2023', Navingo, 28 November 2023 <<https://www.offshorewind.biz/2023/11/28/damen-launches-worlds-first-fully-electric-sov-capable-of-charging-offshore-at-oeec-2023/>> [accessed 12 December 2023]
- Bureau Veritas, 'NR678 hydrogen-fuelled ships' <<https://marine-offshore.bureauveritas.com/nr678-hydrogen-fuelled-ships>> [accessed 10 December 2023]
- Carlaw, A., 'Floating on Air – Air Lubrication' Z' in ShipZERO28 (London: ZESTAs, 2023) <<https://zestas.org/shipzero28/presentations-gallery/#23>> [accessed 14 December 2023]
- Clarksons, 'Fleet Electrification to Increase as Marine Battery Technology Becomes Commercially Viable', Clarksons Securities, November 2022 <<https://www.clarksons.com/home/news-and-insights/2022/fleet-electrification-to-increase-as-marine-battery-technology-becomes-commercially-viable/>> [accessed 9 May 2023]
- Clean Hydrogen Partnership, 'Renewable Hydrogen for Inland Waterway Emission Reduction (RH2IWER)', Clean Hydrogen Joint Undertaking, 2023 <https://www.clean-hydrogen.europa.eu/projects-repository/rh2iwer_en> [accessed 10 May 2023]
- CMB.Tech, 'BEH2YDRO Launches 100% Hydrogen Engines for Heavy-Duty Applications at World Hydrogen Summit in Rotterdam', CMB.Tech News, 2023 <<https://cmb.tech/news/beh2ydro-launches-100-hydrogen-engines-for-heavy-duty-applications-at-world-hydrogen-summit-in-rotterdam>> [accessed 10 May 2023]
- Color Line, 'Color Line Fleet', 2019 <<https://www.colorline-cargo.com/color-line-fleet>> [accessed 4 December 2019]
- Comer, B., Georgeff, E., Stolz, D., Mao, X. and Osipova, L., 'Decarbonizing Bulk Carriers with Hydrogen Fuel Cells and Wind-Assisted Propulsion: A Modeled Case Study Analysis, 2022 <<https://theicct.org/publication/hydrogen-and-propulsion-ships-jan22/>> [accessed 12 May 2023]
- Corvus Energy, 'MF Tycho Brahe', Projects, 2023 <<https://corvusenergy.com/projects/tycho-brahe/>> [accessed 12 May 2023]
- Čučuk, A., 'Everfuel and Greenstat Enter Lease Agreement with Elkem for Hydrogen Hub Agder', Offshore Energy, 3 March 2023 <<https://www.offshore-energy.biz/everfuel-and-greenstat-enter-lease-agreement-with-elkem-for-hydrogen-hub-agder/>> [accessed 12 May 2023]
- , 'Zoning Plan for Gen2 Energy's Hydrogen Facility in Mosjøen Gets Approved', Offshore Energy, 30 March 2023 <<https://www.offshore-energy.biz/zoning-plan-for-gen2-energys-hydrogen-facility-in-mosjoen-gets-approved/>> [accessed 12 May 2023]
- Echandia, 'What Batteries Are Used in Sparky the Tugboat?', Echandia Insights, October 2022 <<https://echandia.se/insights/article/what-batteries-are-used-in-sparky-the-tugboat/>> [accessed 12 May 2023]
- Egil Ulvan Rederi AS, 'Egil Ulvan Rederi New Project "With Orca" a Hydrogen Fuelled Bulk Carrier Project Awarded LR Approval in Principle.', Press Release, 2023 <<https://ulvan-rederi.no/egil-ulvan-rederi-new-project-with-orca-a-hydrogen-fuelled-bulk-carrier-project-awarded-lr-approval-in-principle/>> [accessed 12 May 2023]
- Elkafas, Ahmed G., Massimo Rivarolo, Eleonora Gadducci, Loredana Magistri, and Aristide F. Massardo, 'Fuel Cell Systems for Maritime: A Review of Research Development, Commercial Products, Applications, and Perspectives', Processes 2023, Vol. 11, Page 97, 11.1 (2022), 97 <<https://doi.org/10.3390/PR11010097>> [accessed 12 May 2023]
- Enkhuizen Zeevaartschool, 'Wind Assisted Ship Propulsion', 2023 <<https://www.ezs.nl/wind-assisted-ship-propulsion.html>> [accessed 12 May 2023]
- ETHW, 'Electric Boats', Today's Engineer, 2013 <https://ethw.org/Electric_Boats> [accessed 9 May 2023]
- European Federation for Transport and Environment AISBL, 'EU Agrees to the World's First Green Shipping Fuel Requirement', Transport & Environment (Brussels, 23 March 2023) <<https://www.transportenvironment.org/discover/eu-confirms-the-worlds-first-green-shipping-fuel-requirement/>> [accessed 12 May 2023]

- European Sustainable Shipping Forum, 'Sustainable Power @ MARIN', European Commission, 2023 <<https://sustainablepower.application.marin.nl/well-to-wake>> [accessed 10 May 2023]
- Farges, O., 'State-of-the-Art of Hydrogen Liquefaction', in DOE Workshop (Houston, TX: US Department of Energy, 2022) <[https://www.energy.gov/sites/default/files/2022-03/Liquid H2 Workshop-Air Liquide.pdf](https://www.energy.gov/sites/default/files/2022-03/Liquid%20H2%20Workshop-Air%20Liquide.pdf)> [accessed 12 May 2023]
- Fesmire, J. E. and Swanger, A., 'Overview of the New LH 2 Sphere at NASA Kennedy Space Center', in DOE/NASA Advances in Liquid Hydrogen Storage Workshop (NASA Kennedy Space Center, FL: US Department of Energy, 2021)
- Fincantieri S.p.A., 'Viking Neptune', 2023 <<https://www.fincantieri.com/en/products-and-services/cruise-ships/viking-neptune/>> [accessed 10 May 2023]
- Fincantieri SI, 'ZEUS (ZERO EMISSION ULTIMATE SHIP)', Innovation, 2023 <<https://www.fincantierisi.it/innovation>> [accessed 12 May 2023]
- Thomas, F., Cryogenic Engineering, Revised and Expanded, 2nd edn (Boca Raton: CRC Press, 2004) <<https://doi.org/https://doi.org/10.1201/9780203026991>> [accessed 10 May 2023]
- Garanovic, A., 'Wave energy plant in South Korea to produce green hydrogen', Navigo, 6 June 2023 <<https://www.offshore-energy.biz/wave-energy-plant-in-south-korea-to-produce-green-hydrogen/>> [accessed 12 December 2023]
- gCaptain, 'ABS Issues AIP for an Offshore Hydrogen/Ammonia Production Platform from KRISO', gCaptain, 20 September 2023 <<https://gcaptain.com/abs-issues-aip-for-an-offshore-hydrogen-ammonia-production-platform-from-kriso/#:~:text=An%20offshore%20hydrogen%20and%20ammonia,generated%20by%20a%20wind%20farm.>> [accessed 12 December 2023]
- General Electric, 'GE Power Conversion - Advanced Induction Motor (AIM)', GE Power Conversion, 2023 <<https://www.gpowerconversion.com/product-solutions/induction-motors/Advanced-Induction-Motor-AIM>> [accessed 10 May 2023]
- HESC, 'Port of Hastings', Supply Chain, 2023 <<https://www.hydrogenenergysupplychain.com/supply-chain/port-of-hastings/>> [accessed 12 May 2023]
- Hochschule Emden/Leer, 'Laboratories', 2023 <<https://www.hs-emden-leer.de/en/current-students/faculties/maritime-sciences/research-laboratories-projects/laboratories>> [accessed 12 May 2023]
- HTW Editorial Team, 'Elogen to supply electrolyser for Hollandse Kust Noord offshore wind project' KCI Media Group B.V., 4 July 2023 <<https://hydrogentechworld.com/elogen-to-supply-electrolyser-for-hollandse-kust-noord-offshore-wind-project>> [accessed 12 December 2023]
- Hydrogen Central, 'Veer Receives Support for Wind-Assisted Hydrogen Fuel Cell Vessel Design - Hydrogen Central', Hydrogen Central, October 2022 <<https://hydrogen-central.com/veer-receives-support-wind-assisted-hydrogen-fuel-cell-vessel-design/>> [accessed 12 May 2023]
- HyStra, 'World's First Marine Loading Arm with Swivel Joints for Liquefied Hydrogen Successfully Demonstrated Ship-to-Shore Transfer', News Archives, 2023 <<https://www.hystra.or.jp/en/gallery/article.html>> [accessed 12 May 2023]
- IEA, Global Hydrogen Review 2023 (Paris, 2023) <<https://www.iea.org/energy-system/low-emission-fuels/electrolysers>> [accessed 13 December 2023]
- Innovation Norway, 'Maritime Sector on the Verge of Hydrogen Transformation', Business Norway, 2023 <<https://businessnorway.com/articles/maritime-sector-on-the-verge-of-hydrogen-transformation>> [accessed 12 May 2023]
- International Energy Association, IEA Hydrogen TCP Task 39: Hydrogen in the Maritime (Chapter 6: Review of Hydrogen Propelled Vessels: IEA, 2021)
- International Maritime Organization (IMO), 'Training seafarers for a decarbonized future', Latest news, 6 December 2023, <https://www.imo.org/en/MediaCentre/Pages/WhatsNew-2014.aspx> [accessed 14 December 2023]
- Kawasaki Heavy Industries Ltd., Development of Liquefied Hydrogen Terminal, 2021 <<https://global.kawasaki.com/en/corp/rd/magazine/182/pdf/n182en06.pdf>> [accessed 12 May 2023]
- , 'Special Issue on Hydrogen Supply Chain', Kawasaki Technical Review, 182 (2021) https://www.kawasaki-gasturbine.de/files/KAWASAKI_TECHNICAL_REVIEW_No_182.pdf
- Hansen, K. E., 'Jinling Delivers World's Greenest Ro-Ro Ship', News, 2020 <<https://www.knudehansen.com/news/jinling-delivers-worlds-greenest-ro-ro-ship/>> [accessed 12 May 2023]
- Hansjörg, K. 'AIDAPERLA Will Receive the Largest Battery Storage System in Passenger Shipping in 2020', Carnival Corporation & Plc, 2019 <<https://www.carnivalcorporation.com/news-releases/news-release-details/aidaperla-will-receive-largest-battery-storage-system-passenger>> [accessed 9 May 2023]
- Langeteig, E., 'Hydrogen Supply Chain Infrastructure, A-Z' in ShipZERO28 (London: ZESTAs, 2023) <https://zestas.org/shipzero28/presentations-gallery/#6> [accessed 12 December 2023].
- Linde Engineering, 'Hydrogen Liquefiers', Cryogenic Plants, 2023 <https://www.linde-engineering.com/en/process-plants/cryogenic_plants/hydrogen_liquefiers/index.html> [accessed 12 May 2023]
- Lloyd's Register Group Services Limited., 'World First for Liquid Hydrogen Transportation.', Insights, October 2020 <<https://www.lr.org/en/insights/articles/world-first-for-liquid-hydrogen-transportation/>> [accessed 12 May 2023]
- Mandra, J. O., 'IWSA: More wind-powered ships than large cargo vessels running on low and zero-carbon fuels', Navigo, 5 December 2023 <https://www.offshore-energy.biz/iwsa-there-are-more-wind-powered-ships-than-large-cargo-ships-operating-on-low-and-zero-carbon-fuels/> [accessed 14 December 2023]
- Marine Battery Forum, 'Guideline to Standardisation of Containerized Maritime Battery Systems' <<https://www.maritimebatteryforum.com/news/guideline-towards-standardisation-of-containerized-maritime-battery-systems>> [accessed 10 May 2023].
- Marine Battery Forum, 'MBF Ship Register', 2023 <<https://www.maritimebatteryforum.com/ship-register>> [accessed 9 May 2023]
- Marine Battery Forum, 'Offshore charging is key for all-electric OSVs', News, 1 November 2023 <<https://www.maritimebatteryforum.com/news/offshore-charging-is-key-for-all-electric-osvs>> [accessed 12 December 2023]
- McKinsey & Company, Global Hydrogen Flows, 2022 <www.hydrogencouncil.com> [accessed 12 May 2023]
- , Hydrogen Insights 2023, September 2023 <<https://hydrogencouncil.com/wp-content/uploads/2023/05/Hydrogen-Insights-2023.pdf>> [accessed 12 December 2023]
- MPS, 'Installation Completed', Press Release, 2023 <<https://www.marineperformancesystems.com/news/successful-commissioning-of-berge-toubkal>> [accessed 12 May 2023]
- NCE Maritime CleanTech, Norwegian Future Value Chains for Liquid Hydrogen, 2016 <<https://maritimecleantech.no/wp-content/uploads/2016/11/Report-liquid-hydrogen.pdf>> [accessed 12 May 2023]
- Nergard, J., 'Zero Emission Vessel Electrical system integration' in in ShipZERO28 (London: ZESTAs, 2023) <<https://zestas.org/shipzero28/presentations-gallery/#16>> [accessed 11 December 2023]
- NEUMAN & ESSER GROUP, 'Hydrogen Storage in Salt Caverns', 2023 <<https://www.neuman-esser.de/en/company/media/blog/hydrogen-storage-in-salt-caverns/>> [accessed 12 May 2023]
- NPRC, 'Minister Harbers Gives Go-Ahead for New Construction of Inland Vessel Propelled by Green Hydrogen', 2023 <<https://nprc.eu/minister-harbers-gives-go-ahead-for-new-construction-of-inland-vessel-propelled-by-green-hydrogen/?lang=en>> [accessed 12 May 2023]

- Odenweller, A., Falko U., Gregory F. N., Jensterle, M. and Luderer, G., 'Probabilistic Feasibility Space of Scaling up Green Hydrogen Supply', *Nature Energy*, 7.9 (2022), 854–65 <<https://doi.org/10.1038/s41560-022-01097-4>> [accessed 12 May 2023]
- Østvik, I., 'The world's first Liquid Hydrogen Ferry to Liquid Hydrogen bulk carriers' in ShipZERO28 (London: ZESTAs, 2023) <<https://zestas.org/shipzero28/presentations-gallery/#19>> [accessed 12 December 2023]
- Plug Power, 'Hydrogen Liquefiers', *Hydrogen*, 2023 <<https://www.plugpower.com/hydrogen/hydrogen-liquefier/>> [accessed 12 May 2023]
- PowerCell Group, 'World's Largest Marine Fuel Cell Systems', 2023 <<https://powercellgroup.com/worlds-largest-marine-fuel-cell-systems/>> [accessed 10 May 2023]
- Pragma Industries, 'Hydrogen Storage', 2023 <[https://www.pragma-industries.com/hydrogen-storage/#:~:text=Metal hydride tank is a,on AB5 metal hydride alloys.](https://www.pragma-industries.com/hydrogen-storage/#:~:text=Metal%20hydride%20tank%20is%20a,on%20AB5%20metal%20hydride%20alloys.)> [accessed 10 May 2023]
- Reilly, R., 'Marine Offshore Energy', in ShipZERO28 (London: ZESTAs, 2023) <<https://zestas.org/shipzero28/presentations-gallery/#11>> [accessed 12 December 2023]
- Reuters, 'Japan's Asahi Tanker to Start Ship Fuelling with World's First Electric Tanker', Reuters, 14 April 2022 <<https://www.reuters.com/article/japan-marine-electric-tanker-idUKL3N2WB3NF>> [accessed 9 May 2023]
- Rhine Hydrogen Integration Network of Excellence (RH2INE), 'Towards Zero Emission Transport Corridors', 2023 <<https://www.rh2ine.eu/>> [accessed 9 May 2023]
- Ross, M., 'Sanmar Shipyards delivers second electric tugboat', UKI Media & Events, 18 August 2023 <<https://www.electrichybridmarinetechology.com/news/ferries-and-cruises/sanmar-shipyards-delivers-second-electric-tugboat.html>> [accessed 13 December 2023]
- Samskip, 'Samskip Launches Its Next-Generation Zero-Emission Short Sea Container Vessels', News, 2023 <<https://www.samskip.com/news/samskip-launches-its-next-generation-zero-emission-short-sea-container-vessels/>> [accessed 12 May 2023]
- Schuler, M., 'ONE Adds to Orderbook with Order for Ten Large Containership', gCaptain, 15 March 2023 <<https://gcaptain.com/one-adds-to-orderbook-with-order-for-ten-large-containership/>> [accessed 14 December 2023]
- Ship Nerd, 'Bow Windshield, New Rising Containership Feature', Ship Nerd, February 2023 <<https://www.shipnerdnews.com/bow-windshield-new-containership-feature/>> [accessed 12 May 2023]
- Shippax, 'Leclanché Receives Orders for 22.6 MWh of Battery Systems with Stena RoRo for Two E-Flexers', Shippax, January 2023 <<https://www.shippax.com/en/news/leclanche-receives-orders-for-226-mwh-of-battery-systems-with-stena-line-and-brittany-ferries-for-two-e-flexers.aspx>> [accessed 10 May 2023]
- Sinclair, S., 'Static Offshore Hydrogen Production' in ShipZERO28 (London: ZESTAs, 2023) <<https://zestas.org/shipzero28/presentations-gallery/#5>> [accessed 12 December 2023]
- Sloop, J., 'LIQUID HYDROGEN AS A PROPULSION FUEL, 1945-1959' (NASA SP-4404, 1978) <<https://history.nasa.gov/SP-4404/ch8-11.htm>> [accessed 12 May 2023]
- Stadt AS, 'Lean Drive', Stadt AS, 2023 <<https://www.stadt.no/lean-drive>> [accessed 10 May 2023]
- Stave, H., 'Onboard Hydrogen Systems', in ShipZERO26 (Glasgow: ZESTAs, 2021) <https://vimeo.com/668135738?embedded=true&source=vimeo_logo&owner=158416371> [accessed 10 May 2023]
- Sünnetci, I., 'Type 214TN REIS Class TCG PIRI REIS Submarine', Defence Turkey, January 2020 <<https://www.defenceturkey.com/en/content/type-214tn-reis-class-tcg-piri-reis-submarine-3827>> [accessed 10 May 2023]
- Swanger, A. M., 'Final Test Results for the Ground Operations Demonstration Unit for Liquid Hydrogen', Cryogenics Society of America, Inc., 6 May 2023 <<https://doi.org/10.1016/J.CRYOGENICS.2017.10.008>> [accessed 10 May 2023]
- Switch Maritime, 'SW/TCH Maritime', Projects, 2023 <<https://www.switchmaritime.com/>> [accessed 12 May 2023]
- Teco 2030, 'TECO 2030 with Consortium Finalizes Agreement for EUR 5 Million in HyEkoTank Project', Teco 2030 News, December 2022 <<https://teco2030.no/news/teco-2030-with-consortium-finalizes-agreement-for-eur-5-million-in-hyekotank-project-17951173/>> [accessed 10 May 2023]
- te Siepe, H., 'Hydrogen in Salt as Reusable Energy, Safe Mass Storage and High Efficiency Recycling', in ShipZERO26 (Glasgow: ZESTAs, 2021) <<https://zestas.org/shipzero-26-5/speakers/#hans>> [accessed 10 May 2023]
- ten Cate Hoedemaker, S., Solutions for Large Batteries for Waterborne Transport, 2021
- The International Council on Clean Transportation (ICCT), 'Workshop Summary', in ICCT Technical Workshop on Zero Emission Vessel Technology (San Francisco, CA: ICCT, 2019) <<https://theicct.org/events/zero-emission-vessel-workshop-SF-2019.>> [accessed 12 May 2023]
- The Maritime Executive, 'Air Lubrication Takes Off in LNG Carrier Segment' The Maritime Executive, 23 August 2023 <<https://maritime-executive.com/article/air-lubrication-takes-off-in-lng-carrier-segment>> [accessed 14 December 2023]
- The Maritime Executive, 'Port of Amsterdam Lays Keel for First "Solid Hydrogen" Fueled Vessel', The Maritime Executive, 23 January 2023 <<https://maritime-executive.com/article/port-of-amsterdam-lays-keel-for-first-solid-hydrogen-fueled-vessel>> [accessed 12 May 2023]
- TMC Compressors, 'Market Leading Compressors', Press Release, 2023 <<https://www.tmc.com/>> [accessed 12 May 2023]
- Wavefoil, 'Wavefoil - Retractable Bow Foils', 2022 <<https://wavefoil.com/>> [accessed 12 May 2023]
- WorkBoat 365, 'MJR Power and Automation - World's First "In Air" Offshore Vessel Charging System Completes Successful Harbour Trials', WorkBoat 365, March 2023 <<https://workboat365.com/power-propulsion-news/mjr-power-and-automation-worlds-first-in-air-offshore-vessel-charging-system-completes-successful-harbour-trials/>> [accessed 10 May 2023]
- Yulu PR, 'Shift Clean Energy's PwrSwåp Technology to Be Used in First All-Electric Vessel in One of the World's Busiest Ports', Shift Clean Energy, 28 September 2022 <<https://shift-cleanenergy.com/2022/09/28/shift-clean-energys-pwrswap-technology-to-be-used-in-first-all-electric-vessel-in-one-of-the-worlds-busiest-ports/>> [accessed 10 May 2023]
- ZEM Tech, North Sea Hy-Ships Study Phase 1 (Aberdeen, 2021)
- ZemShips, 'A New Development: The Hydrogen Fuelling Station', Technology, 2008 <<https://web.archive.org/web/20081011063719/http://www.zemships.eu/en/technology/hydrogen-fuelling-station/index.php>> [accessed 12 May 2023]
- Zero Emission Services, 'Charging Infrastructure', 2023 <<https://zeroemissionservices.nl/en/charging-infrastructure/>> [accessed 10 May 2023]
- Zorn, T., Innovation & Experience. Hydrogen Technology and Infrastructure, 2013 <<https://energiforskmedia.blob.core.windows.net/media/18546/aga-linde-h2-dec.pdf>> [accessed 10 May 2023]

Case Studies

Company	Subject	Case study	Page
Leclanché	Yara Birkeland	Case Study 1	2
Leclanché	Wolfe Islander IV, Amherst II	Case Study 2	5
Leclanché	Ellen E-ferry	Case Study 3	8
Shift Clean Energy	M/S Aurora af Helsingborg	Case Study 4	10
ABB	Herjólfur IV	Case Study 5	13
Corvus	Nesvik, Havila Castor, Barcelona, North Sea Giant	Case Study 6	16
NAVTEK	ZEETUG30 & ZEETUG45	Case Study 7	18
SEAM	Oslofjord I-V	Case Study 8	19
Various	Hydra, Waal, H2 Barge 1, Zulu	Case Study 9	21
Wabtec	FerryCHARGER specifications	Case Study 10	22
Shift Clean Energy	PwrSwäp specifications	Case Study 11	24
Leclanché	Navius specifications	Case Study 12	27
Echandia	Echandia Energy & Echandia Power specifications	Case Study 13	30
Corvus	Orca specifications	Case Study 14	34
Nedstack	MT FCPI 500 specifications	Case Study 15	36
Ballard Power	FCWave specifications	Case Study 16	37
Hydrogenics	HyPM90 specifications	Case Study 17	39
Luxfer	Gaseous hydrogen tank specifications	Case Study 18	40
Various	Norled, Unitrove, CMB	Case Study 19	42
Argo-Anleg	Swappable gaseous hydrogen tank specifications	Case Study 20	45
Kawasaki Heavy	Liquid hydrogen tank & truck specifications	Case Study 21	47
Dealfeng	Lead time for rotor sails	Case Study 22	50
Silverstream	Silverstream System - Hull air lubrication	Case Study 23	51
Hull Vane	Hull Vane	Case Study 24	55
Wattlab	Onboard solar performance	Case Study 25	60
Incat Tasmania	Hull 096	Case Study 26	62
Damen	Pure electric Service Operations Vessel design	Case Study 27	63
Shift Clean Energy	Hydromover	Case Study 28	65
LH2 Shipping	Short sea hydrogen-powered cargo ship	Case Study 29	67
Future Proof Shipping	H2 Barge 1: Operations & life onboard	Case Study 30	68
LH2 Shipping	MF Hydra: Operations & life onboard	Case Study 31	69
Dealfeng	JUN BAI 56 rotor sail installation	Case Study 32	70
eConowind	Ventofoil sails	Case Study 33	71
Strathclyde University	GATERS Project	Case Study 34	72

Autonomous Container Feeder Vessel

YARA Birkeland



Powering the world's first fully electric and autonomous container vessel with a Leclanché 6.7MWh Marine Battery System

The Technology

With over 200 patents in lithium-ion (Li-ion) battery cell technology and production, Leclanché batteries deliver exceptional safety, longevity and cycle life. Leclanché battery systems and cells are manufactured in automated facilities in Germany and Switzerland and in compliance with the highest environmental standards.

The Marine Rack System (MRS) provided by Leclanché for the Yara Birkeland is a modular and scalable Li-ion battery system for marine applications. It uses high energy Li-ion G/NMC cells with unique features, including bi-cell laminate design and ceramic separators, to ensure optimal performance.

The cells are fitted into robust modules packaged into IP65-rated enclosures designed for harsh maritime environments. The enclosures are assembled into the MRS with a dedicated, in-house designed battery management system.



An example of one of the Marine Rack Systems (MRS) as fitted on the Yara Birkeland

Safety is a Priority

The Leclanché MRS was developed in conjunction with DNV-GL and certified by all other major certification authorities (RINA, Bureau Veritas and Lloyd's Register).

- The MRS features a fully certified active fire extinguishing system.
- Multi-layer safety measures on a cell, module and system level, tested and certified against mechanical, thermal and electrical abuse.
- Our MRS fire suppression system offers protection against all unexpected external hazards (electrical, mechanical and thermal).
- Automatic extinguishing system uses independent heat- and smoke/gas-triggering sensors to prevent false alarms and improve reactivity
- The battery system is redundant, with four separate battery rooms: if one or more of the strings are emptied or stop working, the vessel can continue its operations.



IP65 enclosure with battery module and integrated cooling plate

Vessel Details

	Yara Birkeland
Vessel Type	Open Hatch Container Feeder
Battery System	MRS (55Ah G/NMC)
Battery Energy (MWh)	6.7
Dimensions (L x W, m)	80 x 15
Cargo Capacity	120 TEU
Operation date	2021
CO ₂ emissions during operation	Zero

The Vessel Diagram

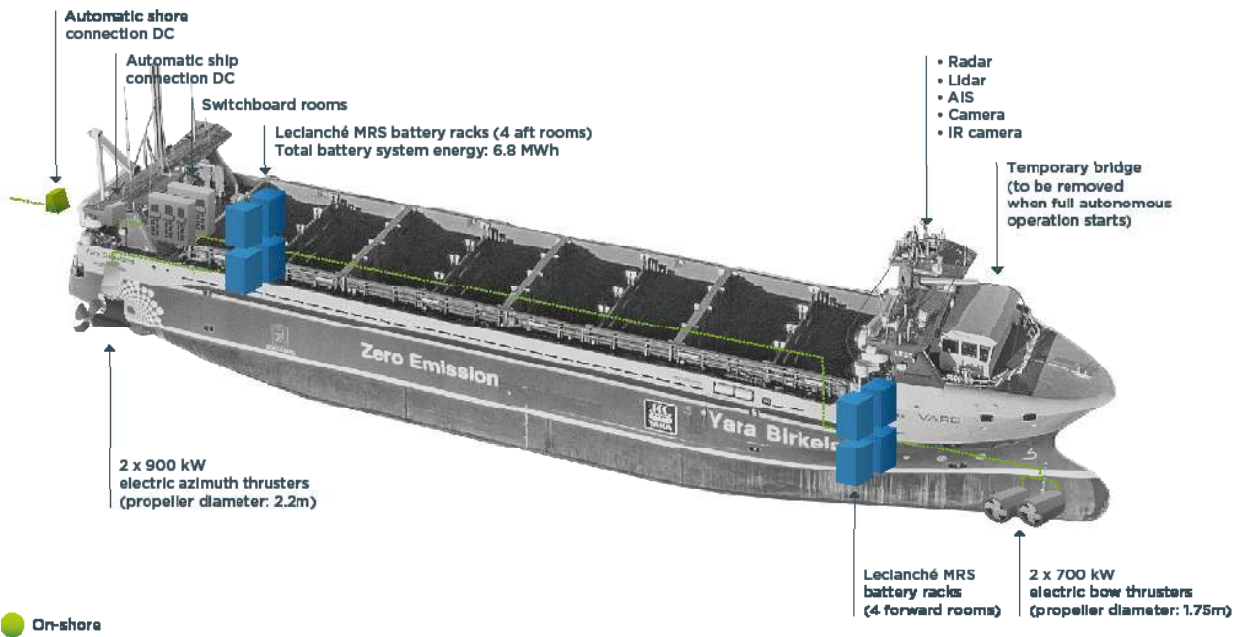

“We are very proud to be able to contribute to the success of this unique project with our technology and our experience from the e-marine sector. With our battery system for the Yara Birkeland, we are once again enabling an important step towards more emission reduction and climate neutrality in the field of maritime shipping”.

Anil Srivastava
Chief Executive Officer (CEO) of Leclanché

The Certificates

The Leclanche Marine Rack System was first certified in 2017 by DNV and was the first marine battery system to obtain this approval. Since then, it has received numerous additional class approvals from major certification authorities.

in progress:



Photos of vessel courtesy of Knut Brevik Andersen

Leclanché E-Mobility SA
(Headquarters)
Avenue des Découvertes 14 C
1400 Yverdon-les-Bains
Switzerland

Leclanché GmbH
Industriestrasse 1
77731 Willstätt
Germany

Leclanché North America, Inc.
2685 Enterprise Dr
Anderson, IN 46013
USA

Leclanché Norway
Karenslyst alle 53
0279 Oslo
Norway

www.leclanche.com
info@leclanche.com



WE ARE ENABLING THE ENERGY TRANSITION

Zero Emission Ferry and Onshore Battery Energy Storage System

Amherst Islander II & Wolfe Islander IV



Combined onboard and onshore energy storage system for the first electric newly built passenger and car ferry in North America.

The Challenges



The electrification of transportation is expanding at a fast pace and that includes the maritime sector where a growing list of countries are requiring the electrification of ferries.

Fully electric ferries reduce emissions – and noise (especially important within the harbor) – as well as operational costs. Passenger ferries, which travel relatively short distances, are ideal for fully electric operation.

To meet tight travel timetables, ferries are docked for only a limited time. For electric ferries, this means they require high-power charging, however, the electric grids in harbor communities are often limited and unable to cope with the required high loads for vessel-charging. This was the situation at Millhaven and Stella harbors, both on the Lake of Ontario, Canada.

The Solution

The solution was the development of a first-of-its-kind, combined onboard and onshore energy storage solution enabling hybrid and fully electric vessels to recharge quickly when returning to port.



Vessel

The Amherst Islander II & Wolfe Islander IV will be the first newly built passenger/car ferries in North America with the ability to operate in a fully electric manner. The main propulsion is provided by an array of Leclanché marine battery systems, with 1.9 MWh (Amherst Islander II) and 4.6 MWh (Wolfe Islander IV) energy capacity. The Amherst Islander II will travel, silently and without emissions, at 9 knots and the Wolfe Islander IV at 11 knots, which matches conventional propulsion.

Vessel Details

	Amherst Islander II	Wolfe Islander IV
Vessel Type	Damen 6819 E3 -	Damen 9819 E3
Battery System	Leclanché MRS9 (55Ah)	Leclanché MRS9 (60Ah)
Battery Energy (kWh)	1,900	4,600
Dimensions (L x W, m)	71.7 x 20.2	98.4 x 20.2
Passenger/Car Capacity	300 / 40	399 / 80
Operation date	2021	2021
CO ₂ saving per year (estimated vs previous vessel type)	7,000 tonnes	

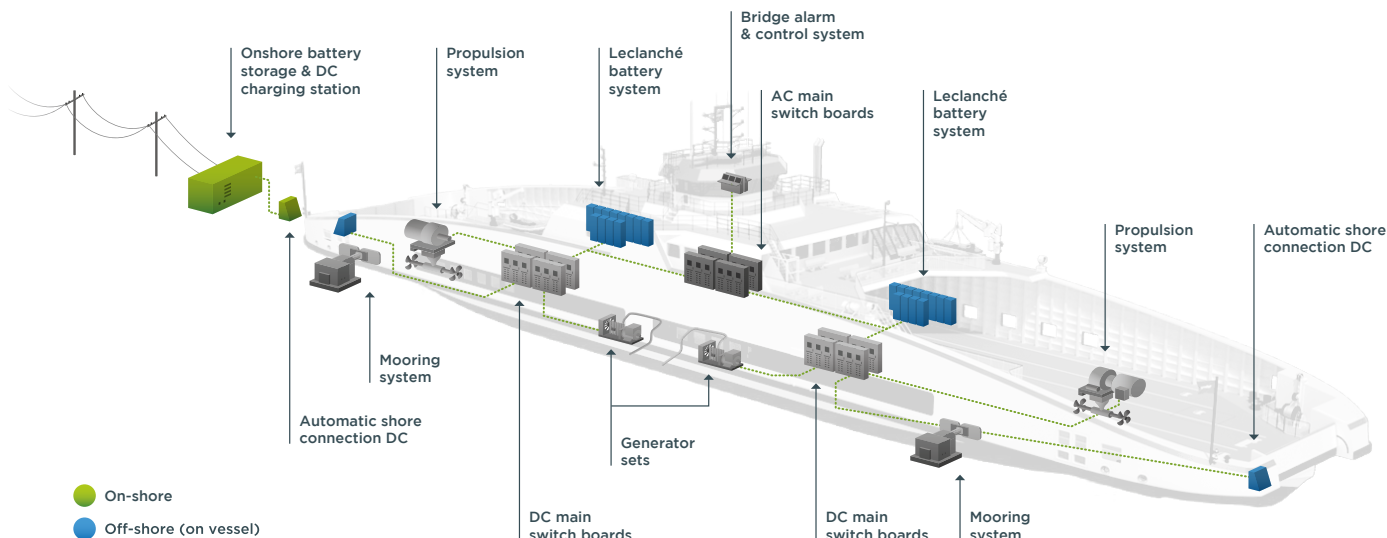

Amherst Island Route

	Millhaven	Stella
BESS Energy (kWh)	5,900	4,400
Battery discharge Continuous DC Power (kW)	4,800	4,800
Battery discharge Continuous AC Power (kW)	1,400	800
Power Conversion System (DC/AC) between grid and battery (kVA)	1,500	1,000
Conversion system (DC/DC) between battery and ferry (kW)	3,600	3,600
Grid Voltage (V)	600	600

Wolfe Island Route

	Kingston	Marysville
BESS Energy (kWh)	5,900	4,400
Battery discharge Continuous DC Power (kW)	4,800	4,800
Battery discharge Continuous AC Power (kW)	1,400	800
Power Conversion System (DC/AC) between grid and battery (kVA)	1,500	1,000
Conversion system (DC/DC) between battery and ferry (kW)	3,600	3,600
Grid Voltage (V)	600	600

Certificates

The **Leclanche Marine Rack System** was first certified in 2017 by DNV and was the first marine battery system to obtain this approval. Since then, it has received numerous additional class approvals from major certification authorities.

in progress:



Cover image shows DAMEN Road Ferry 9819 E3 «Wolfe Islander IV»

www.leclanche.com

info@leclanche.com

WE ARE ENABLING THE ENERGY TRANSITION



E-ferry

The world's largest*
fully electric ferry



Serving commercial and industrial customers, utilities and transport with high quality battery storage systems since 1909.

The E-ferry is the world's* largest zero emission, fully electric ferry and is the result of an EU funded project.

Date of operation :	2019
Battery system :	4.3 MWh, G-NMC
Charging power :	3.9 MW DC
Propulsion power :	1.5 MW (2 x 750 kW)
Dimensions :	59.4m (length), 13.4m (width)
Capacity :	31 cars or 5 HGV trucks & 8 cars
Country of operation :	Denmark
Battery service life :	10 years
Maximum speed :	15.5 knots
Propulsion motor :	Liquid cooled electric motor (Synchronous reluctance assisted permanent magnet technology)
Light ship weight :	650 tons
Passengers :	198

* At time of construction

Leclanché Energy Storage Systems were selected to power the world's largest electric ferry, the E-ferry. With a 4.3MWh capacity, the E-ferry sets a new benchmark in marine propulsion applications. It will operate between the islands of Aero & Als in southern Denmark.



Replacing a diesel ferry results in annual emissions savings of :

- 2000 tons CO₂
- 42 tons NO_x
- 2.5 tons of particulates
- 1.4 tons SO₂.

The battery system provided by Leclanché uses high energy lithium-ion G-NMC cells with unique safety features including bi-cell laminate design and ceramic separators to ensure performance does not come at the cost of safety. Leclanché develops and manufactures its own cells with both graphite/NMC (Lithium Nickel Manganese Cobalt oxide) and LTO (Lithium Titanate Oxide) technologies.

Parallel, redundant battery and drivetrain systems makes the E-ferry exceedingly safe and reliable.

The E-ferry has been designed with uniquely integrated battery and drivetrain systems providing unparalleled operating efficiencies.

The Technology

With over 100 patents in lithium-ion battery cell technology and production, Leclanché batteries deliver exceptional safety, longevity and cycle life. Leclanché battery systems are manufactured in Germany & Switzerland, in compliance with the highest environmental standards.

Part of the EU Horizon 2020 initiative

The E-ferry is part of Danish Natura project aimed at providing green transport for local residents. This project has received funding from the European Union's Horizon 2020 Research and Innovation Program under grant #636027.



Leclanché SA (Headquarters)

Avenue des Sports 42
CH - 1400 Yverdon-les-Bains
Switzerland

Leclanché GmbH

Industriestrasse 1
D - 77731 Willstätt
Germany

Leclanché North America, Inc.

1920 Purdue Pkwy
Suite 100
Anderson, IN 46016, USA

www.leclanche.com

info@leclanche.com



**STATIONARY
SOLUTIONS**



**e-TRANSPORT
SOLUTIONS**



**SPECIALTY BATTERY
SYSTEMS**

WE ARE IN CHARGE



Client
ForSea

Project Date
Completed in 2017

Project Information
Category: Ferry
System: 4160 kWh
Country: Sweden



CASESTUDY

FORSEA *ELECTRIC FERRY*

All Electric. 8,414 Tonnes.

The Aurora is a fully electric passenger ferry. It measures 111 m and weighs 8,414 tonnes. It operates on a 4 km ferry route between Helsingborg (Sweden) and Helsingör (Denmark). The massive ship carries 7.4 million passengers and 1.9 million vehicles annually.

The system is comprised of 640 6.6 kWh batteries installed on top of each ferry in containers. Cables run from the containers to connecting points at each end of the ship.

Charging: All pre-docking procedures are based on 3D laser scanning and wireless communication between ship and shore. During the last 400 mm of the ferry's approach the robot will reach out and pull the shore cable

from the ship. The cable reel releases the cable and the robot moves the connectors to the corresponding connectors below the robot. After the connection is made, the robot moves back to the home position and the roll-up doors closes. The robot will reside inside its own building when not in use.

ZERO EMISSIONS



ForSea Ferries have chosen to charge their batteries with “green electricity”, from non-fossil fuel sources such as wind, water and solar energy. This means that there are no emissions from the battery-operated vessel.



The system is comprised of 640 6.6 kWh batteries installed on top of each ferry in containers. Cables run from the containers to connecting points at each end of the ship.



Shift

HQ R&D and Product Development
1200 W 73rd Ave Suite 606, Vancouver, Canada
T +1 (778) 819-1898
info@shift-cleanenergy.com
www.shift-cleanenergy.com

HQ Europe

Shift Clean Energy ApS
Lautrupsgade 7, 3. tv.
2100 København Ø
denmark@shift-cleanenergy.com



SHIFT
+ 2 CLEAN ENERGY



MARCH 7TH 2023

ABB Marine & Ports

Electric vessels

Jorulf Nergård – VP Market Development

ABB solution

Ferries

Examples; Heilhorn(2021)- Herjolfur(2019)



System example

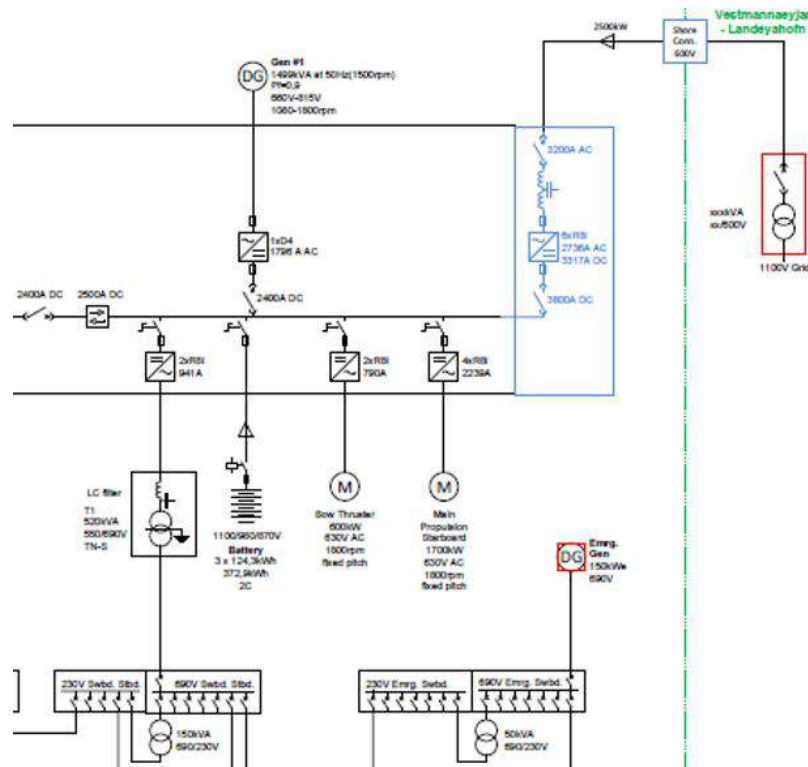

- Ferries, w/batteries and H2 FC
- Onboard DC Grid based Hybrid solution with large batteries of size 1500-4000kWh
- E.g., DnV +1A1, CAR FERRY B, E0, R3(nor) and IS, Battery (Safety)
- Auto-charging with high power 2,5MW from Stemmann.
- Autodocking will be required
- Propulsion power; 2x800-2000kW
- TRL level 9



ABB Reference projects

Hydrogen Fuel cell technology demonstrators and pilots

Maritime Fuel Cell Project by Hydrogenics (2017)

A 100 kW pilot container for U.S Coast Guard



Fuel Cell Technology Demonstrator (2017)

100 kW fuel cell installation for Royal Caribbean Cruise Lines



MARANDA (EU H2020) arctic research vessel

A prototype of 165 kW fuel cell system onboard a research vessel Aranda



FLAGSHIPS (EU H2020) river vessel

400 kW fuel cell installation on a vessel for Compagnie Fluviale de Transport (CFT)





The use of Energy Storage Systems (ESS) has for the past decade developed to be a well-established technology to reduce emissions from shipping. Corvus Energy has supplied systems to more than 650 vessels and logged more than 5,000,000 operating hours. Smaller ships that can charge often, can be all-electric whilst larger ships can be battery-hybrid. Batteries are also an important part of future fuel technologies like fuel cells.

The use of battery systems for large vessels offers several benefits, including:

- !! Fuel savings: ESS can help reduce the fuel consumption of large vessels by providing an alternative source of power for propulsion and onboard systems.
- !! Cost savings: This can result in significant cost savings over time, particularly as the cost of fuel continues to rise aswell as the future cost of CO2 emissions. Maintenance costs are also most often reduced as engines are run on a more optimal load, in addition to lower running hours
- !! Emission reductions.: ESS enables zero emission operation and can help reduce fuel consumption in various ways to reduce the environmental impact of large vessels.
- !! Improved efficiency: ESS can provide an additional power source for large vessels, allowing them to operate more efficiently and with greater flexibility.
- !! Enhanced safety: ESS can provide backup power for essential systems such as navigation and communication, improving safety and reducing the risk of accidents in the event of a blackout.

Experience from vessels in operation

						
	Nesvik Car ferry	Havila Castor Small/mid size cruise	Cisas Power Tug	Libas Purse Seiner & Trawler	MS Cruise Barcelona RO-PAX	North Sea Giant OCV
	Full electric, 1582 kWh	Hybrid, 6102 kWh	Full electric, 1424 kWh	Hybrid, 508 kWh	Hybrid, 5469 kWh	Hybrid, 2034 kWh
Estimated annual reduction in Co ² emission	3857 ton	7500 ton	213 ton	534 ton	2670 ton	5500 ton
Typical reduction potential for vessel type	From 20% up to 100%	15-20% Up to 100% for some voyages	Up to 100%	10 – 30+%	10-30+% Up to 100% for some routes	15-20%

Outlook

As Energy Storage System (ESS) solutions are continuously being developed further, the energy density is increasing, making it possible for more segments, including larger

vessels, to operate fully electric and emission-free. Additionally, ESS solutions will play a crucial role in facilitating other zero-emission fuels and solutions, such as Fuel Cells and the use of hydrogen or ammonia as fuel.

Corvus Energy has taken well proven hydrogen fuel cell technology from Toyota and are developing inherently gas safe marine fuel cells for ships which will be launched in June 2023. It has approval in principle from DNV as inherently gas safe (as described in the IGF code) and is planned to have Type Approval as inherently gas safe by the end of 2023. A pilot installation is planned on a vessel during 2023.

Fuel Cell Pack, -technical data

- Power Output 1 pack: 320 kW
- 1400 x 2050 x 2400 mm (WxDxH)
- 2500 kg.
- Type approval **Inherently Gas Safe**
- Technology partner TOYOTA's with more than 26 000 units produced

Main Service overhaul interval:
30,000 hrs

Applications:

- New builds, under deck
- Retrofit (containerized solution)





ISO container



Gas safe machinery space



Rules and Technology readiness level

Almost all classification societies have certification requirements for Energy Storage Systems (ESS) and specifications for their installation on ships. The first set of provisional rules from a classification society was released in 2013. Additionally, organizations such as IEC have developed relevant standards and are continuously working to improve them.

Corvus Energy's ESS technology is regulated by most Recognized Organizations (ROs), has already been installed on over 650 vessels, and is readily available with type approval certificates. Consequently, the Technology Readiness Level (TRL) of the technology is set at 9.

NAVTEK's ZEETUG Fleet at GİSAŞ Port

In Tuzla, Istanbul, GİSAŞ Port operates the world's first true zero-emission tugboat fleet – the ZEETUG series, developed, designed, and built by NAVTEK Naval Technologies INC.

																																																																																							
NV712-ZEETUG30 IN OPERATION	NV717-ZEETUG30 IN OPERATION	NV719-ZEETUG45 IN OPERATION	NV720-ZEETUG30 IN OPERATION																																																																																				
<table border="1"> <tr><td>Lenght (O.A)</td><td>Abt.</td><td>18.70 m</td></tr> <tr><td>Breadth (MLD)</td><td>Abt.</td><td>6.70 m</td></tr> <tr><td>Depth (MLD)</td><td>Abt.</td><td>4.65 m</td></tr> <tr><td>Draught (Design)</td><td>Abt.</td><td>3.50 m</td></tr> <tr><td>Speed at Design Draught</td><td></td><td>10 knots</td></tr> <tr><td>Electric Motor</td><td></td><td>2x925 kW</td></tr> <tr><td>Personel Number</td><td></td><td>4 Persons</td></tr> </table>	Lenght (O.A)	Abt.	18.70 m	Breadth (MLD)	Abt.	6.70 m	Depth (MLD)	Abt.	4.65 m	Draught (Design)	Abt.	3.50 m	Speed at Design Draught		10 knots	Electric Motor		2x925 kW	Personel Number		4 Persons	<table border="1"> <tr><td>Lenght (O.A)</td><td>Abt.</td><td>18.70 m</td></tr> <tr><td>Breadth (MLD)</td><td>Abt.</td><td>6.70 m</td></tr> <tr><td>Depth (MLD)</td><td>Abt.</td><td>4.30 m</td></tr> <tr><td>Draught (Design)</td><td>Abt.</td><td>3.15 m</td></tr> <tr><td>Speed at Design Draught</td><td></td><td>10 knots</td></tr> <tr><td>Electric Motor</td><td></td><td>2x925 kW</td></tr> <tr><td>Personel Number</td><td></td><td>4 Persons</td></tr> </table>	Lenght (O.A)	Abt.	18.70 m	Breadth (MLD)	Abt.	6.70 m	Depth (MLD)	Abt.	4.30 m	Draught (Design)	Abt.	3.15 m	Speed at Design Draught		10 knots	Electric Motor		2x925 kW	Personel Number		4 Persons	<table border="1"> <tr><td>Lenght (O.A)</td><td>Abt.</td><td>26.20 m</td></tr> <tr><td>Beam (MLD)</td><td>Abt.</td><td>10.60 m</td></tr> <tr><td>Depth (MLD)</td><td>Abt.</td><td>4.32 m</td></tr> <tr><td>Extreme Draught (MLD)</td><td>Abt.</td><td>4.55 m</td></tr> <tr><td>Estimated Top Speed</td><td></td><td>12 knots</td></tr> <tr><td>Electric Motor</td><td></td><td>2900 kW</td></tr> <tr><td>Personel Number</td><td></td><td>8 Persons</td></tr> </table>	Lenght (O.A)	Abt.	26.20 m	Beam (MLD)	Abt.	10.60 m	Depth (MLD)	Abt.	4.32 m	Extreme Draught (MLD)	Abt.	4.55 m	Estimated Top Speed		12 knots	Electric Motor		2900 kW	Personel Number		8 Persons	<table border="1"> <tr><td>Lenght (O.A)</td><td>Abt.</td><td>18.70 m</td></tr> <tr><td>Breadth (MLD)</td><td>Abt.</td><td>6.70 m</td></tr> <tr><td>Depth (MLD)</td><td>Abt.</td><td>4.30 m</td></tr> <tr><td>Draught (Design)</td><td>Abt.</td><td>3.15 m</td></tr> <tr><td>Speed at Design Draught</td><td></td><td>10 knots</td></tr> <tr><td>Electric Motor</td><td></td><td>2x925 kW</td></tr> <tr><td>Personel Number</td><td></td><td>4 Persons</td></tr> </table>	Lenght (O.A)	Abt.	18.70 m	Breadth (MLD)	Abt.	6.70 m	Depth (MLD)	Abt.	4.30 m	Draught (Design)	Abt.	3.15 m	Speed at Design Draught		10 knots	Electric Motor		2x925 kW	Personel Number		4 Persons
Lenght (O.A)	Abt.	18.70 m																																																																																					
Breadth (MLD)	Abt.	6.70 m																																																																																					
Depth (MLD)	Abt.	4.65 m																																																																																					
Draught (Design)	Abt.	3.50 m																																																																																					
Speed at Design Draught		10 knots																																																																																					
Electric Motor		2x925 kW																																																																																					
Personel Number		4 Persons																																																																																					
Lenght (O.A)	Abt.	18.70 m																																																																																					
Breadth (MLD)	Abt.	6.70 m																																																																																					
Depth (MLD)	Abt.	4.30 m																																																																																					
Draught (Design)	Abt.	3.15 m																																																																																					
Speed at Design Draught		10 knots																																																																																					
Electric Motor		2x925 kW																																																																																					
Personel Number		4 Persons																																																																																					
Lenght (O.A)	Abt.	26.20 m																																																																																					
Beam (MLD)	Abt.	10.60 m																																																																																					
Depth (MLD)	Abt.	4.32 m																																																																																					
Extreme Draught (MLD)	Abt.	4.55 m																																																																																					
Estimated Top Speed		12 knots																																																																																					
Electric Motor		2900 kW																																																																																					
Personel Number		8 Persons																																																																																					
Lenght (O.A)	Abt.	18.70 m																																																																																					
Breadth (MLD)	Abt.	6.70 m																																																																																					
Depth (MLD)	Abt.	4.30 m																																																																																					
Draught (Design)	Abt.	3.15 m																																																																																					
Speed at Design Draught		10 knots																																																																																					
Electric Motor		2x925 kW																																																																																					
Personel Number		4 Persons																																																																																					

The ZEETUG30s and ZEETUG45 are outfitted with state-of-the-art 1423.8 kWh and 2214.8 kWh lithium-ion battery packs respectively, courtesy of CORVUS Energy, a front-runner in class-approved marine batteries. These tugs show that high-performance and environmental stewardship can be achieved simultaneously.

Addressing the critical issue of port pollution, where tugboats have traditionally been responsible for a large share of harbour emissions, the ZEETUG fleet is a game-changer. By operating on fully electric propulsion, these tugs eliminate the emission of particulate matter, nitrogen oxides, and sulphur oxides, substantially contributing to the reduction of the carbon footprint at GİSAŞ Port. The fleet proves that true zero-emission maritime operations are not just a vision but a present-day reality.

Over the past three years, the first ZEETUG30 has successfully completed daily heavy-duty operations at GİSAŞ Port, setting an impressive track record of environmental and economic benefits. The transition to electric propulsion has not only minimised operational costs but has also proven to be a significant step forward in curbing greenhouse gas emissions.

In terms of operational experience, the ZEETUGs outperform their diesel-powered counterparts with noticeably reduced noise and vibration levels. Their interiors are thoughtfully crafted for comfort and user-friendliness, paired with advanced manoeuvring capabilities that enhance operational efficiency.

Certification by Türk Loydu (TL) was awarded to the new ZEETUG30 and for ZEETUG45, by DNV-GL and TL, underscoring the safety and performance of these vessels. NAVTEK adheres to the highest standardisation for equipment selection and the attainment of critical certifications, including the Interim Certificate of Class, Bollard Pull Test Certificate, and International Tonnage Certificate.

Oslofjord Vessels I-V

Emission free island tours

SEAM's delivery of e-SEAMatic® BLUE with battery system to Oslofjord vessels I-V – five, 35m passenger vessels with a total capacity of 350 passengers.

The vessels were delivered to Boreal Asset AS by Sefine Shipyard in December 2021 as a new build passenger ferry, **a total of five vessels to operate between the islands in the Oslofjord.**

The vessels will operate fully electric with power from the battery pack. All public transport in the Oslo region aims to be emission free by 2028, the Oslofjord vessels accomplished this goal already in 2022.

SEAM deliveries consist of our sophisticated e-SEAMatic® BLUE series concept, which includes e-SEA® Drive power conversion, batteries, transformers, an integrated automation system and main switchboards on the vessel. The vessel is driven by a battery pack at 1017kWh. The Oslofjord vessels will be charged by the e-SEA® Pantograph, which can be seen as the end of a whale tail at Aker Brygge, Oslo.



Main data

Vessel name:	Oslofjord I-V
Vessel type:	Ro-Ro/Passenger vessel
Owner:	Boreal Asset AS, Norway
Yard:	Sefine Shipyard, Turkey
Year of delivery:	2022

e-SEAMatic® BLUE (Fully electric vessel)

- e-SEAMatic® IAS & EPMS
 - e-SEA® Drive
- SEAM delivery:
- Battery System
 - e-SEA® Switchboard
 - Transformers
 - e-SEAMatic® Shore Charging Stations
 - e-SEA® Pantograph

- Key benefits:
- Reduced noise and vibration.
 - Reduced CO₂- and NO_x-emissions
 - Greater redundancy
 - Lower maintenance cost
 - Improved dynamic performance
 - High efficiency
 - Low weight
 - Small volume

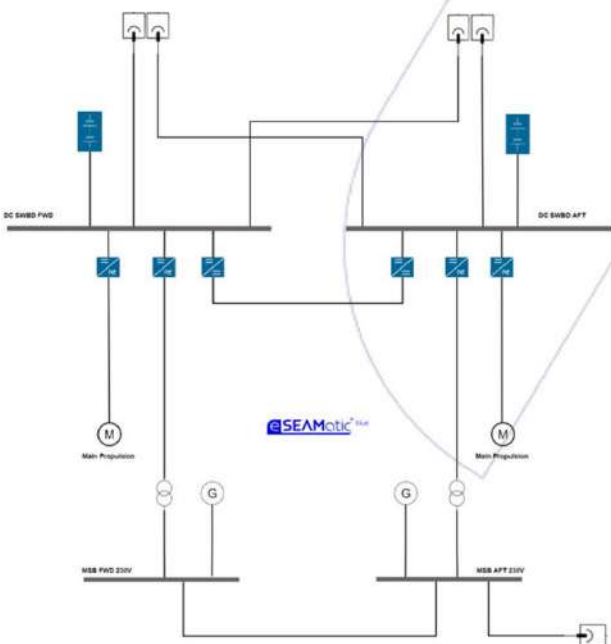



MF Hydra

The 82.4m Hydra RoPax ferry has been commercially operated by Norled since March 2023 carrying 300 passengers and 80 cars. It has a range of 1,000 nm on a full 80m³ tank (4,000 kg fuel) at route speed (10 knots). The vessel has approvals from flag and class using the IMO alternative design process to prove LH2 as a maritime fuel. The vessel features 2 x 200kW FCwave® fuel cells by Ballard Power Systems and generators of 2 x 440kW powering two Schottel thrusters.

Maritime demand for liquid hydrogen is expected to accelerate now that technology is approved by flag and DNV. TRL level is 9.

For Hydra, Norled aims to emit close to zero boil-off during operations. The physical fact that there is a small heat inleak to the LH2 storage is catered for in design where overpressure is removed from the gas-phase of the tank and led to the vaporizer producing gas to the fuel cells. This way there are zero losses during operation.

FPS Waal

The second Flagships vessel, the FPS Waal, is owned and operated by the Netherlands-based Future Proof Shipping. Like Zulu 06, FPS Waal will also have six Ballard FCwave™ fuel cells retrofitted, amounting to a total fuel cell capacity of 1.2 MW.

It features 1 tonne of gaseous containerised hydrogen storage provided by Air Liquide.

The 109.8-meter-long inland container cargo vessel will enter operation on the route between Rotterdam (NL) and Duisburg (DE) on the river Rhine in the beginning of 2024.

This agreement will see the 109.8 x 11.40 x 3.53 m FPS Waal receive. As the world's first DNV type-approved

fuel cell module for marine applications, FCwave™ uses proven technology from Ballard's heavy-duty module platform to deliver reliable performance, high power density and favourable economics.

The vessel has a cargo capacity of 200 TEU.

H2 Barge 1

H2 Barge 1 was retrofitted and operating commercially in the beginning of June 2023.

It features 1 tonne of gaseous containerised hydrogen storage provided by Air Liquide. Nedstack provided by 825 kW fuel cell system using PEMGEN300 modules. The 110m container inland vessel has a 192 TEU cargo capacity.

The bunkering method is compressed hydrogen in 40 foot storage units carried on the deck of the FPS Maas. The provider of H2 containers, H2 container logistics and the certified green hydrogen is Air Liquide for the FPS Maas.

Zulu 06

Ballard Power Systems Europe has been granted Design Review Attestation from classification society Bureau Veritas for the two 200kW FCwave™ fuel cell modules that will be installed on board the Flagships project vessel Zulu 06.

The Zulu 06 will operate a route on the river Seine between Gennevilliers – Bonneuil Sur Marne in Paris, France. Compagnie Fluvial de Transport will operate the vessel for shipowner Sogestran.

FerryCHARGER

Reliable solutions to electrify your crossing



Shortest charging time for sustainable fleets – Solutions adaptable to ship and land side

For every vessel which needs to be in service with 100% reliability, charged fast, when space on ship and land is limited. **Where connection time is critical** regardless of tidal flux and weather, Wabtec solutions with Stemann-Technik technology is the answer. We are the market leader in charging applications, experienced manufacturer that provides dependable high-power charging.



Short time charging
With power up to 23MW



Fully automated fast connection and charging
Connection even below 10s



Automated movement compensation
Safe charging during tidal flux



Increased safety
No operator needed with fully automated connection



Small footprint
Adaptable on shore and receptacle



Broadest portfolio
Know-how with largest installed base worldwide

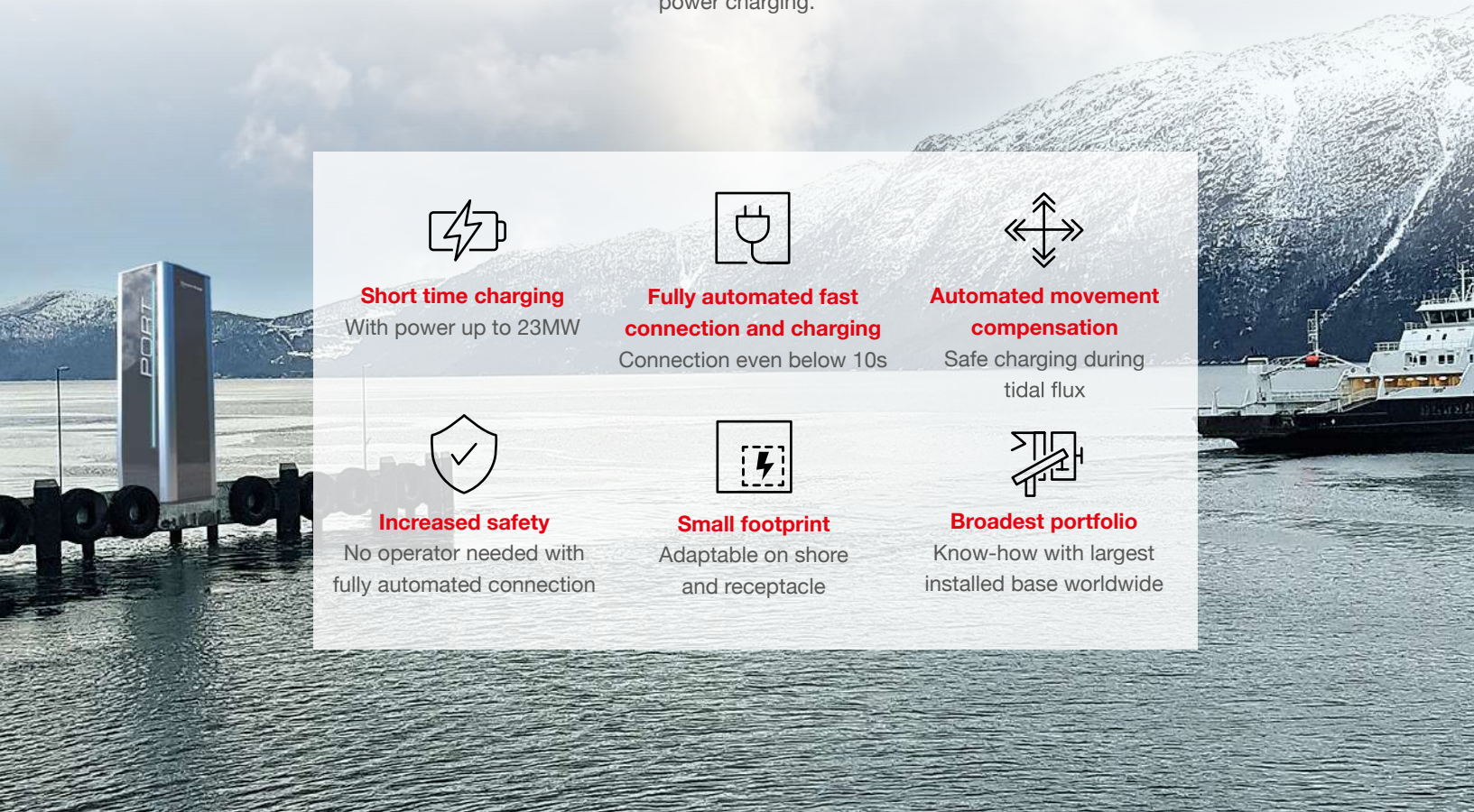



- Largest experience and installed devices
- Expertise in supporting to choose best fit solution to terminal shape and vessel
- Unique high voltage solutions
- Adaptation for country specific demands

Duty cycle up to 100%*	PANTO type top / side	TOWER type	BOW type
Rated voltage	Up to 1000 V AC and 1500 V DC	Up to 1000 V DC and AC Up to 15 kV AC	Up to 1000 V AC and DC Up to 15 kV AC
Nominal current	Up to 1500 A	Up to 3kA at 1kV Up to 900A at 15kV	Up to 5kA DC and 3kA AC at 1kV. Up to 600A at 15 kV
Max Power	2,5 MW at 1kV AC (3ph) 2,2 MW at 1,5kV DC	5MW at 1kV; 23MW at 15kV	5 MW at 1kV 15 MW at 15kV
Connection time	<10s	<10s	<15s
Set-up land	Panto from top/side, telescopic from side	Arm in tower	Arm beside ramp
Set-up ship	Contact bars on roof /side	Enclosed socket (receptacle)	Enclosed socket (receptacle)
Connection	Automated, berth at specific location	Automated, socket detection, only side	Automated, socket detection, front/rear
Vertical (tidal) compensation	1 200mm / or Length of contact bars at Vessel	5 000 mm	8 500 mm
Horiz. lateral compensation	± 310mm / or width of carbon brushes at Panto	± 300 mm	±1 500 mm depends on configuration
Horiz. longitud. compensation	± 280mm / 1 450 mm	1 600 mm	±1 500 mm depends on configuration
Main benefits	Simple, effective for short distances, compact size.	Short charging time. High voltage option. Good berthing tolerances	Small footprint on ramp, compact size, largest movement compensation

*Duty Cycle 100% according to DNVGL-RU-SHIP-Pt4Ch8Se2



PwrSwäp

A first of it's kind - Pay-As-You-Go Service.

Delivering clean and reliable renewable energy with no risk. Typical energy storage barriers of cost, size, weight and charging times are all drastically reduced.

We bring together proven technologies and provide something no one else has: a clean energy ecosystem of swapable batteries that deliver power when and where customers need it. This integrated approach can electrify ports, terminals, inland waterways, ship fleets, industrial sites and even entire isolated communities.

Shift covers the cost which means customers don't have to invest in expensive up-front capital costs.



PwrSwäp

PwrSwäp SPECIFICATIONS



PwrSwäp offers fully charged ePod battery cartridges which are connected through cloud-based service and management centres.

It's simple: use energy from the ePods to power your ship or equipment, then exchange them for new, fully charged ones. ESS is sized per trip, not for the life of the vessel.

Customers save money from day one, while meeting climate action goals through electrification.

Energy Storage Capacity	50kWh	70kWh	140kWh	210kWh	280kWh
Overall Height	1850mm	2150mm	2150mm	2150mm	2150mm
Overall Width	770mm	770mm	770mm	1150mm	1500mm
Overall Depth	720mm	720mm	1250mm	1250mm	1250mm
Weight	700kg	850kg	1700kg	2550kg	3550kg
Lifting Arrangement	Vertical	Vertical or Horizontal	Vertical or Horizontal	Vertical	Vertical
Number of BBUs	6 (100V)	8 (100V)	8 (200V)	12 (200V)	16 (200V)
System Voltage Maximum	600VDC	800VDC			
System Voltage Minimum	465VDC	620VDC			
Lithium Cell Type	NMC				
Manufacturing Standard	A60 Machinery Space				
IP Rating	IP67				
Impact Rating	3G				
Liquid Cooling	Yes				
OnWatch Software	Yes				
Fire Proof	Yes				
Built in Fire Detection	Yes				
Built in Fire Management	Yes				
Interface	Automated Connection w/ power, cooling, ventilation, communications				
Remote Monitoring w/ GPS Tracking	Yes				
Shock and Temperature Sensor	Yes				
External Fire Rating	1000°C@60 minutes minimum				



Shift

HQ R&D and Product Development
1200 W 73rd Ave Suite 606, Vancouver, Canada
T +1 (778) 819-1898
info@shift-cleanenergy.com
www.shift-cleanenergy.com

HQ Europe

Shift Clean Energy ApS
Lautrupsgade 7, 3. tv.
2100 København Ø
denmark@shift-cleanenergy.com



SHIFT
+ 2 CLEAN ENERGY

Navius MRS-3

Marine Battery System



High performance,
European-made
lithium-ion battery
system for marine
applications.

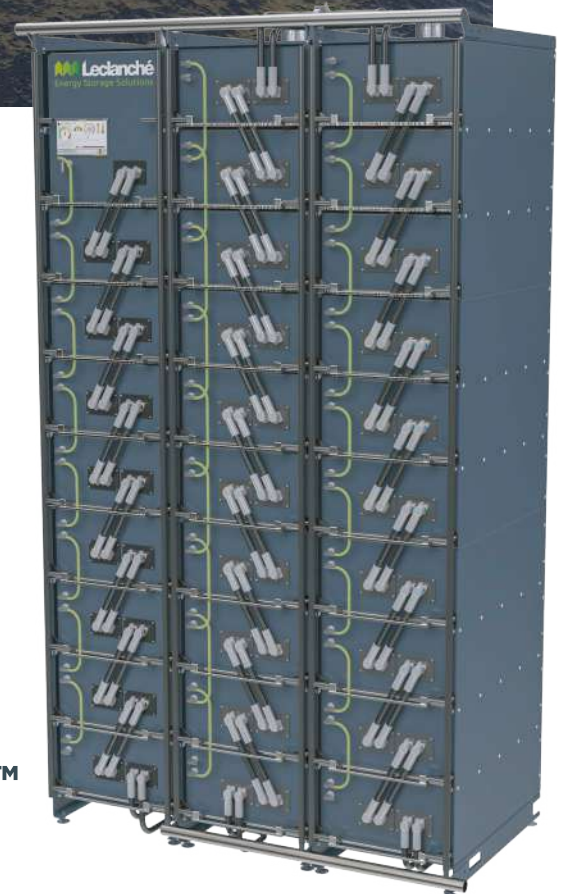

MRS-3TM

System Configurations

The Navius MRS-3 battery racks are available in 7 different heights, ranging from 845mm to 2,350mm (including the exhaust duct), which enables them to fit perfectly into nearly all battery room sizes, whatever the vessel type.

The lowest “H3” variant contains up to 3 modules and the tallest “H10” variant up to 10 modules.

A number of racks are combined into a string – each containing a dedicated Battery Management System. Strings are then combined to create a complete system providing the required energy of the vessel application. Strings with differing heights can be combined into a system if required.

The Navius MRS-3 employs a new architecture which enables it to offer a 50% improvement in battery room installed energy capacity compared to our previous generation MRS-2 system.

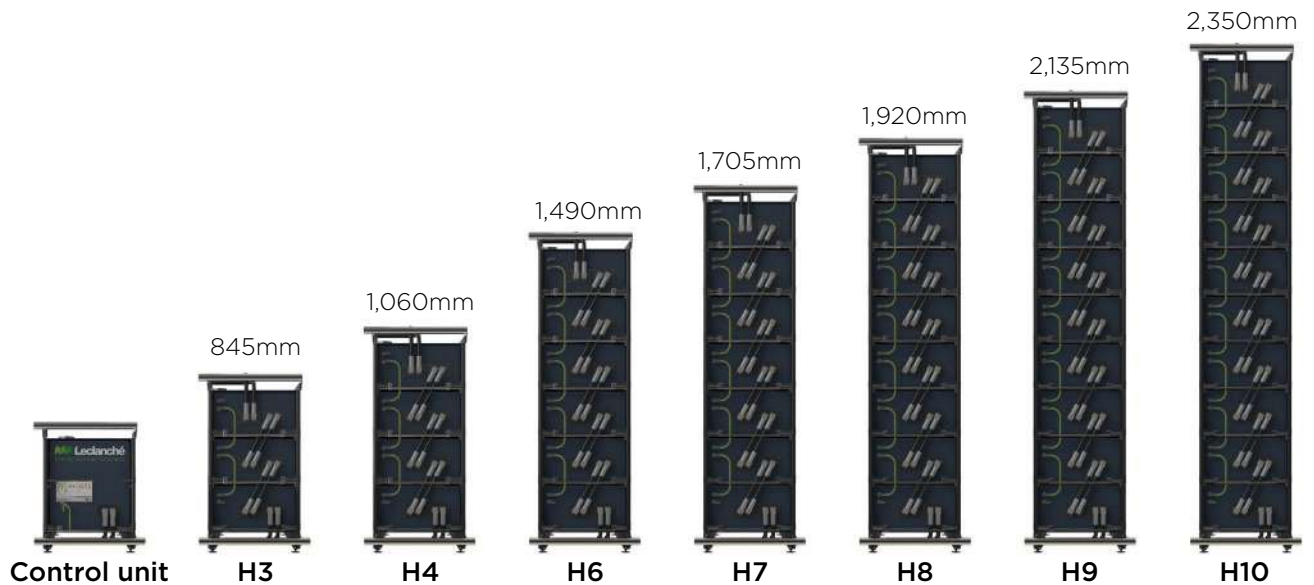

System Specifications

Rack Heights (Note: 125mm installation clearance is required)	H3: 845mm, H4: 1,060mm, H6: 1,490mm, H7: 1,705mm, H8: 1,920mm, H9: 2,135mm, H10: 2,350mm
Rack Width & Depth	W 435mm, D 710mm
Rack Weights including Energy Modules	H3: 251kg, H4: 327kg, H6: 478kg, H7: 554kg, H8: 630kg, H9: 707kg, H10: 738kg
Rack Weight including Energy Modules & Control Unit ²	H3: 153kg, H4: 229kg, H6: 380kg, H7: 456kg, H8: 532kg, H9: 609kg, H10: 685kg
Single Module Energy / Nominal Voltage	8.7 kWh / 33.6V to 67.1V
Single String ³ Max. Voltage)	1200V
Max. Gravimetric Density - Rack / String ³	111 / 108 Wh/kg
Max. Volumetric Density - Rack / String ³	120 / 112 Wh/litre
Max. Energy Density footprint - Rack / String ³	282 / 263 kWh/m ²

Performance Specifications

C-Rate - Peak - (Discharge / Charge)	4.6C / 3.0C ¹
C-Rate - Continuous - (Discharge / Charge)	2.8C / 1.0C ¹
Cycle Life (80% DoD)	7,000 cycles (65Ah G/NMC cell)

Example System 1

System Configuration	4 strings ³ each comprising of 5 x H7 Racks (with 65Ah cell)
Energy	1,079 kWh
Voltage (Min / Nom / Max)	837 V / 1038 V / 1172 V
Dimensions & Weight (Depth x Width x Height / Mass)	708 x 8,600 x 1,762mm / 9,362 kg
Energy Density	115 Wh/kg / 105 Wh/litre

Example System 2

Rack Types	20 strings ³ each comprising of 3 x H10 Racks (with 65Ah cell)
Energy	4,875 kWh
Voltage	756 V / 937 V / 1058 V
Dimensions & Weight (Depth x Width x Height / Mass)	708 x 25,800 x 2,407mm / 41,946 kg
Energy Density	116 Wh/kg / 115 Wh/litre

Safety Specifications

Thermal Runaway Anti-Propagation	Active Safety System
Disconnect Circuit	String level with HV breakdown
Short Circuit Protection	Fuses at battery string level.
Emergency Stop Circuit	In line with class requirements
Ground Fault Detection	Integrated in each battery string
Disconnect Switchgear Rating	400A / 800A (continuous)

General Specifications

Communication Protocol	CAN or Modbus
Class Compliance (Planned)	DNV, BV, RINA, LR, ABS
Ingress Protection	IP44
Cooling	Liquid-Cooled

¹ Dependent on module configuration used.

² When a Control Unit (consisting of BMS and Switching) is fitted to a rack, it takes the space of 2 modules.

³ A string comprises of a number of sets of battery racks. Strings are combined in parallel to create the complete battery system.

Technical Data Sheet

ECHANDIA ENERGY & ECHANDIA POWER



Echandia

www.echandiagroup.com

Heavy-Duty Energy Storage Solutions

Technical Data Sheet – 1st of January 2022

ECHANDIA ENERGY

ECHANDIA POWER

Echandia is leading the development of maritime electrification, with zero-emission energy solutions for maritime and industrial applications.

Echandia delivers heavy-duty battery systems and proprietary, lightweight battery racks and system architecture for complex and demanding environments.

Flexible and modular

Flexible and modular rack system to meet any vessel requirements. Inherently safe using the safest battery chemistry on the market. Flexible system capacity and voltage levels based on application.

Certified for the maritime world

Echandia actively promotes and engages in certification and type approval to meet the highest possible industry standards. We have type approval for LTO-based battery systems from both DNV and Bureau Veritas.



Echandia Energy

E-LTO ENERGY

Description

The High Energy system is ideally suited for applications that require safe operation and long lifetime under heavily cycling conditions over longer durations, typically 6 minutes or longer per cycle.

The unique LTO cell technology used enables a greater portion of installed capacity to be utilized, resulting in a more compact, lighter and cost-effective system for a given duty cycle

Applications

Full electric propulsion

Performance

Peak max current per string (Discharge / Charge)	400 A / 400 A for 10 s
Continuous max current per string (Discharge / Charge)	160 A / 160 A
Life-time 2C Discharge / Charge to 80% EOL	50 000 cycles at 50% DoD
Usable capacity (% of installed)	90% (5% - 95% SOC)
Weight	Example: 13800 kg for 1068 kWh @ 1000 Vmax

Safety

Thermal runaway anti-propagation	Cell level. Verified in accordance with DNV-GLPt-6, Ch-2/ NMA RSV 12
Integrated Fire Suppression	Not required. Verified in accordance with DNV-GLPt-6, Ch-2/ NMA RSV 12
Fault Detection	Over- & under- voltage, over-temperature
Short Circuit Protection	Breaker on string level
Emergency Stop Circuit	Hard wired
Disconnect Breaker Rating	Max string short circuit contribution at full load

General

Class Compliance	All Classification Societies
EMC compliance	DNV/BV: based on IEC 60945, IEC 61000-4-X, CISPR 16-2-1 & CISPR 16-2-3
Type Approval	DNV, Bureau Veritas
BMS Communication	CAN2.0b, MODBUS TCP and PROFINET
Cooling	Forced air
Vibration and Shock	DNV requirements plus dampers always selected to comply with vessel's specification
Pre-charge circuit	Integrated

Echandia Power

E-LTO POWER

Description

The High-Power system is ideally suited for hybridization applications where high power is required under shorter periods of time, typically 5 minutes or under per cycle.

The unique LTO cell technology used enables a greater portion of installed capacity to be utilized, resulting in a more compact, lighter and cost-effective system for a given duty cycle.

Applications

Spinning reserve, peak shaving, load levelling, cranes etc.

Performance

Peak max current per string (Discharge / Charge)	550 A / 550 A for 100 s
Continuous max current per string (Discharge / Charge)	400 A / 400 A for 300 s, 160 A / 160 A > 300 s
Life-time 2C Discharge / Charge to 80% EOL	70 000 cycles at 50% DoD
Usable capacity (% of installed)	90% (5% - 95% SOC)
Weight	Example: 4770 kg for 274 kWh @ 1000 Vmax

Safety

Thermal runaway anti-propagation	Cell level. Verified in accordance with DNV-GLPt-6, Ch-2/ NMA RSV 12
Integrated Fire Suppression	Not required. Verified in accordance with DNV-GLPt-6, Ch-2/ NMA RSV 12
Fault Detection	Over- & under- voltage, over-temperature
Short Circuit Protection	Breaker on string level
Emergency Stop Circuit	Hard wired
Disconnect Breaker Rating	Max string short circuit contribution at full load

General

Class Compliance	All Classification Societies
EMC compliance	DNV/BV: based on IEC 60945, IEC 61000-4-X, CISPR 16-2-1 & CISPR 16-2-3
Type Approval	DNV, Bureau Veritas
BMS Communication	CAN2.0b, MODBUS TCP and PROFINET
Cooling	Forced air
Vibration and Shock	DNV requirements plus dampers always selected to comply with vessel's specification
Pre-charge circuit	Integrated



Corvus Orca Energy

The Orca Energy ESS represented a shift in the maritime industry when launched in 2016. No other Energy Storage System can compete with the installation count of the Orca Energy system. Outstanding results and the highest level of safety has set the new industry-standard for maritime batteries.

When launched, Corvus Energy combined its industry-leading research and development capabilities with several years of experience from having the largest global installed base of ESS solutions to build the industry's safest, most reliable, high performing and cost-effective maritime ESS.

Applications

Orca Energy is ideal for applications that are in need of both energy and a high amount of power, moving large amounts of energy at an inexpensive lifetime cost per kWh. Typical vessel-types are:

- Ferries
- Cruise ships
- Ro/Ro – Ro/Pax
- Yachts
- Offshore vessels
- Rigs
- Tugs
- Fishing vessels
- Merchant vessels
- Port cranes
- Shore charging
- Fish farms

Features

- High C-Rate – up to 3C continuous
- Installed on 250+ vessels around the world
- Designed for voltages up to 1200 VDC
- Low installation and commissioning time
- Low life cycle cost
- Enhanced reliability with contained power connections
- Flexible and modularised design
- Passive single-cell Thermal Runaway protection
- Scalable capacity and voltage according to vessel requirements
- Industry-proven Battery Management System (BMS)
- Remote monitoring capabilities
- Enhanced EMI immunity design for maritime environments

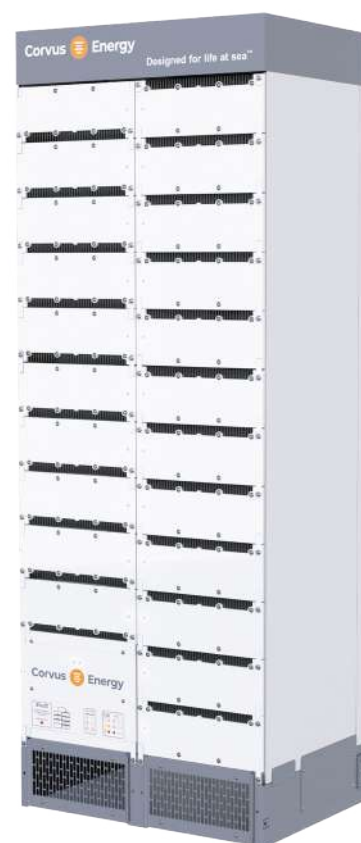

Corvus Energy safety innovations

Passive-Single - Cell-level Thermal Runaway (TR) Isolation

- True cell-level thermal runaway isolation
- TR does not propagate to neighbouring cells
- Isolation NOT dependant on active cooling

Exceeds Class and Flag standards TR Gas venting

- Integrated thermal runaway gas exhaust system
- Easily vented to external atmosphere rather than the battery room



Technical Specifications | Corvus Orca Energy

Performance Specifications

C-Rate - Peak (Discharge / Charge)	Project Specific Values
C-Rate - Continuous (Discharge / Charge)	Up to 3C / Up to 3C

System Specifications

Single Module Size / Increments	5,6 kWh / 50 VDC
Single Pack Range	38-136 kWh / 350-1200 VDC
Max Gravimetric Density - Pack	77 Wh/kg 13 kg/kWh
Max Volumetric Density - Pack	88 Wh/l

Example Packs

Energy	124 kWh (249 kWh for Tall Pack)
Voltage	Max: 1100 VDC Nom: 980 VDC Min: 800 VDC
Dimensions - Vertical Pack - 124 kWh	Height: 2241 mm Width: 865 mm Depth: 738 mm 1628 kg
Dimensions - Horizontal Pack - 124 kWh	Height: 1260 mm Width: 1730 mm Depth: 738 mm 1726 kg
Dimensions - Tall Pack - 249 kWh	Height: 3000 mm Width: 1345 mm Depth: 738 mm 3375 kg

Example System - 8 Vertical Packs

Energy	992 kWh
Voltage	Max: 1100 VDC Nom: 980 VDC Min: 800 VDC
Dimensions - 8 x 124 kWh	Height: 2241 mm Width: 6920 mm Depth: 738 mm 13 024 Kg

Safety Specifications

Thermal Runaway Anti-Propagation	Passive cell-level thermal runaway isolation with exhaust gas system
Fire Suppression	Per SOLAS, class and Corvus recommendation
Disconnect Circuit	Hardware-based fail-safe-for over-temperature and over-voltage
Short Circuit Protection	Fuses included on pack level
Emergency Stop Circuit	Hard-wired
Ground fault Detection	Integrated
Disconnect switchgear rating	Full load

General Specifications

Class Compliance	DNV GL, Lloyds Register, Bureau Veritas, ABS, RINA
Type Approval	DNV GL, Bureau Veritas, ABS, RINA
Ingress Protection	System: IP44
Cooling	Forced air
Vibration and Shock	UNT38.3, DNV 2.4, IEC 60068-2-6
EMC	IEC 61000-4, IEC 60945-9, CISPR16-2-1



PemGen[®]

MT-FCPI-500



The MT-FCPI-500 is a Maritime Fuel Cell Power Installation intended as a zero-emission shipping enabler. It offers a compact and robust LT-PEM power supply option for a large variety of maritime applications, both on inland waterways or in short-sea domain. The PemGen Fuel Cell Power System portfolio is available on a configure-to-order basis. Get in touch to tune this system to your application.



GENERAL	Fuel Cell Type	Low Temperature Proton Exchange Membrane (LT-PEM)
	Fuel Cell Model	60 x Nedstack FCS 13-XXL
ELECTRICAL	Nominal Power	500 kW _e
	Peak Power (BoL)	626 kW _e
	Voltage range	500 - 1000 VDC
	Current range	0 - 1200 A
ENCLOSURE	Weight	15.000 kg
	Built Level	20 ft ISO Container (High Cube)
	Length	6.06 m
	Width	2.44 m
	Height	2.90 m
	IP-rating	IP 54
	HYDROGEN FEED	Quality
Supply pressure		0.3 – 6 barg
Nominal consumption (BoL)		59 kg/ MWh _e
Max consumption		40 kg/h
COOLANT	Medium	DI water or BASF FC G20
	Outlet Temperature	Max 65 °C
	Required Cooling Capacity	900 kW _{th}
	Recoverable heat	>400 kW _{th}
AMBIENT CONDITIONS	Operating Temperature	-10 - 40 °C
	Storage Temperature	5 - 60 °C (optional -20 °C – 60 °C)
APPLICATION	Intended use	Main Propulsion Power for smaller vessel APU Source for Larger vessel
	Placement	Containerized when on open deck Skid based integration below deck
	Balance of Plant	20 years
	Stack Refurbishment	24k - 30k running hours
COMPLIANCY	Standards	Class Approval on Request IEC-60092 IEC-60529 IEC-60533 IEC-62282-3



Fuel Cell Power Module for Marine Applications

Ballard's 200kW system, FCwave™, is designed to provide zero-emission power to vessels. The culmination of product development and field experience based on more than 100 million kilometers of heavy-duty vehicle operation, FCwave™ uses proven technology from Ballard's heavy duty module portfolio to deliver reliable performance, high power density and favorable economics.

Ballard's FCwave™ is developed and tested for marine environments, and is the world's first DNV Type Approved Fuel Cell for marine applications. The system is scalable from 200kW to MWs to suit a broad range of vessels operating on short or longer and demanding routes.



Features

Modular, Scalable Power

Available in 200kW increments, FCwave™ facilitates scalable power output and flexible integration onto the vessel.

Low Lifecycle Cost

Low total-cost-of-ownership, achieved through product performance optimization, common components across product platforms and low maintenance requirements.

Long Lifetime

Powered by Ballard's FCgen®-LCS heavy duty liquid cooled stack and designed to deliver long term performance.

Ease of Integration

The system is integrated into a clean-lined cabinet with easy access doors and all interfaces accessible from the front for service and maintenance.

Safe Operation

Designed hand-in-hand with the industry to withstand the rigors of the marine environment, FCwave™ is developed, tested and prepared for installation with an uncompromising focus on safety.

Remote Diagnostics

Diagnostics connection allows the customer to monitor performance data remotely and plan for preventative maintenance.

Technology Leadership

The same Ballard fuel cell technology powering FCwave™ is already proving itself in more than 3,600 fuel cell electric trucks and busses deployed in China, Europe and North America.

Product Specifications

Performance

Rated power	200kW
Minimum power	55kW
Peak fuel efficiency	53.5%
Operating voltage	350 - 720 V DC
Rated current ¹	2 x 300 A or 1 x 550 A
System cooling output	Max 65° C

Stack technology

Heat management	Liquid cooled
H ₂ Pressure	3.5 - 6.5 barg

Physical

Dimensions (L x w x h) ²	1209 mm x 741 mm x 2195 mm
Weight (estimate) ³	1000 kg
Environmental protection	IP44
Engine room (DNV CG-0339)	+0°C - +45°C
Minimum start-up temperature	0°C
Short-term storage temperature	-40°C - +60°C

Reactants and Coolant

Type	Gaseous hydrogen
Composition	As per SAE spec. J2719 and ISO 14687:2019 Type I, Type II - Grade D
Oxidant	Air
Composition	Particulate, Chemical and Salt filtered
Coolant ⁴	Water or 50/50 glycol

Safety Compliance

Certifications	DNV-Type Approval
Enclosure	Sealed secondary barrier for hydrogen

Monitoring

Control interface	Ethernet, CAN
-------------------	---------------

Emissions

Exhaust	Zero-emission
---------	---------------

¹ System Output (1x550A output pending tests). ² Target size. ³ Includes: framed skid base, fuel cell stacks, plumbing and wiring, H₂ enclosure, cooling system, air system, electrical panel, and miscellaneous (sensors, cable tray, etc.). ⁴ Customer coolant type.

HyPM™ HD 90

Heavy Duty Fuel Cell Power Module

- Liquid-cooled advanced MEA PEM stack
- Integral Balance of Plant
- Advanced onboard controls and diagnostics
- Comes with low pressure cathode air delivery
- -46 °C sub-zero shutdown capability

Technical Data

Rated Electrical Power	99 kW continuous
Operating Current	0 to 500 A _{DC}
Operating Voltage	180 to 360 V _{DC}
Peak Efficiency	55% ¹⁾
Response	< 5 s from off to idle < 3 s from idle to rated power
Fuel	Hydrogen >99.98%
Oxidant	Ambient Air
Coolant	De-ionized water (DI H ₂ O) or 60% ethylene glycol / DI H ₂ O
Ambient Temperature	-10 to +55 °C operating -40 to +65 °C storage (<2 °C with automated freeze shutdown feature)
Communication Interface	CAN v2.0A (standard 11 bit)

¹⁾ Efficiency based on LHV of H₂, 25°C, 101.3 kPa, including onboard parasitic loads, excluding radiator fan and water pump



- Rapid start-up and dynamic response
- Unlimited start-stop cycling
- Robust, rugged and reliable
- No water for humidification required
- No nitrogen required for shutdown

Physical

Dimensions L x W x H ²⁾	955 x 1525 x 345 mm
Mass ³⁾	327 kg
Volume ³⁾	502 L

²⁾ Excluding air delivery and optional water pump

³⁾ Including air delivery and optional water pump

Includes

- Air delivery unit (low pressure blower)
- Integration and operation manual
- Product Warranty

Options

- Coolant pump
- Thermal management kit
- Diagnostics software
- Power electronics components

Applications

- Urban transit buses
- Heavy duty commercial fleet vehicles
- Industrial trucks
- Marine
- Aerospace

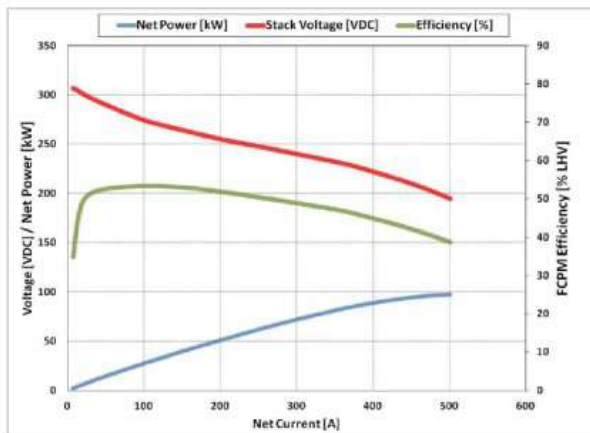

HyPM™ HD90 Typical Performance¹⁾

Actual delivered product may differ in appearance.
Specifications subject to change without prior notification.
Printed in Canada © Hydrogenics Corporation 2012-04-16

HYDROGENICS Corporation
220 Admiral Blvd, Mississauga, Ont, L5T 2N6 Canada
Tel. +1 (905) 361 3660 Fax +1 (905) 361 3626

HYDROGENICS GmbH
Am Wiesenbusch 2, 45966 Gladbeck, Germany
Tel. +49 (2043) 944 133 Fax +49 (2043) 944 146

www.hydrogenics.com
fuelcellsales@hydrogenics.com



Specification Data:
G-Stor™ H2 Alternative Fuel Cylinders



Giving you more innovation

Luxfer's G-Stor H2 products are the leading line of lightweight high-pressure hydrogen storage cylinders.

G-Stor™ H2

FOR FUEL CELL VEHICLES

Luxfer's G-Stor H2 products are the leading line of lightweight high-pressure hydrogen-storage cylinders used by a number of the world's largest OEMs that design, develop and manufacture state-of-the-art compressed hydrogen-storage systems for fuel-cell applications.

The G-Stor H2 advantage is our lightweight, impermeable Type 3 cylinder technology. It is also available with Luxfer's proprietary high-pressure hydrogen electronic solenoid valve, resulting in a certified, cost-effective hydrogen-storage solution that is ideal for fuel cell transit buses, heavy-duty trucks, vans, bulk gas transport, and forklifts.

Numerous hydrogen-storage systems are fitted with G-Stor H2 cylinders and valves, for instance fuel-cell transit buses and commercial vehicles.

Our cylinders were also used on hydrogen-powered commuter buses during the Summer Olympics in London, and we continue to supply H₂ systems around the world. G-Stor H2 is the ideal solution for applications requiring fill pressures up to 10,153 psi (700 bar) to increase fuel range.

Benefits of G-Stor H2

- Lightweight.
- Zero permeation.
- Fast-fill capability.
- Operating pressures ranging from 5,076 psi (350 bar) to 10,153 psi (700 bar).
- Available with Luxfer's Electronic Solenoid Valve (ESV) high-precision gas-flow control (pictured).



Benefits of Hydrogen

- Significantly safer to store than liquid fuels – leaks will disperse into the air instead of on the ground.
- If created by water electrolysis using renewable energy such as solar, then greenhouse gases are eliminated.
- Fuel cell vehicles offer a near-silent operation and reduced maintenance with no moving engine parts.
- Water is the only byproduct from a fuel cell vehicle.

H ₂ capacity	Service pressure	Water volume	Diameter	Length	Tank weight	Total weight tank + fuel	Thread size	Neck mount	Part #
kg	bar	l	mm	mm	kg	kg			
0.7	350	29	281	730	17	17.7	2.000-12UN-2B	No	L028H35
0.8	350	34	281	830	19	19.8	2.000-12UN-2B	No	L034H35
0.9	350	39	281	926	21	21.9	2.000-12UN-2B	No	L039H35
2.3	350	94	340	1458	48	50.3	2.000-12UN-2B	No	Q095H35
1.6	350	68	399	850	37	38.6	2.000-12UN-2B	No	V068H35
1.8	350	74	399	900	39	40.8	2.000-12UN-2B	No	V074H35
3.6	350	150	415	1614	74	77.6	2.000-12UN-2B	Yes	W150H35
4.9	350	205	415	2110	95	99.9	2.000-12UN-2B	Yes	W205H35
7.8	350	322	415	3165	141	148.8	2.000-12UN-2B	Yes	W322H35
2.13	700	53	332	1161	58	60.1	2.000-12UN-2B	No	M053H70

All cylinders are dual-ported, unless otherwise noted, with boss thread connection = 2.000-12UN-2B.

Other sizes and custom cylinder lengths and size configurations are available upon request with minimum order. Approved pressure relief device must be used for fire protection.

Cylinder specifications are nominal values and are subject to change without notice.

Hydrogen Bunkering Case Studies

Liquid Hydrogen Bunkering

Norled



Norled mobile bunkering tower delivering liquid hydrogen to Hydra RoPax ferry using trailer.

Bunkering solutions developed, TRL 9.

Norled bunkering system:

- Loading rate 3 ton/hr, rate can be increased to 4-5 tons/hr for next project
- Tower is moveable but it can also be a fixed port structure if space in port/quay is available
- Bunkering time on Norled Hydra We will spend 1-1,5 hrs all in all during operation
- Dimensions (footprint area, height) Area is 4*5m and height is app 12m
- Weight app 15 tons
- No pumps or power is utilised. We use overpressure in trailer to push LH2 over to ship.

During bunkering we have developed a system that emits very little and it is only pressure released from the bunkering tower and truck (app. 10-15 kg) out of an LH2 load of 3.2-3.5 tons. For the next version of the bunkering system, we will aim to collect this "stranded" gas and use it locally. During transport, Linde Gas has no boil-off or losses.

The hydrogen fuel is delivered by tube truck from a 24 MW green electrolyser in Germany by Linde while Norwegian supply catches up with demand.

Unitrove



Unitrove mobile bunkering system as presented at COP26 in Glasgow, UK.

TRL 5

The LH2 delivery from our Cryogenic pump will be in the region of 500 litres/min (30,000 litres/hr or 2100 kg/hr).

The unit is a 4-stage pump driven by a 6.5KW motor.

With a back pressure of say 4 bars, the delivery pressure will be in the region of 6.5 bars.

The minimum flow rate of the pump is roughly 250 litres/min (15,000 litre/hr 1050 kg/hr). The delivery pressure will be around 7.3 bars.

The unit at COP26 will weigh in the region of 1-1.5 tonnes. This will be for bunkering the ship only. The footprint is in the region of 1m x 1.8m x 2.5m tall.

The unit will consist basically an Emerson LH2 coriolis metre, break-away coupling including pre-alarm system, valves, Gas detector and alarm etc..

For the development of the ZEMFS if we integrate the 3 modules (Submerged pump + HP Reciprocating + storage note: in development) all contained within a 40-foot ISO container this will weigh in the region of 15-20 tonnes. As for the electrical charging, still in development this could be on a separate module to ensure safe separation distance.

Gaseous Hydrogen Bunkering

CMB.Tech



CMB.Tech fixed multi-modal gaseous hydrogen bunkering facility.

CMB.Tech multi-modal refuelling station in Antwerp, Belgium, which dispenses at two hydrogen bunkering pressures for vessels at 200 and 350 bar and a tube trailer filling station at 500 bar.

1002136 (500 bar 12 tanks bundle) ELEKTRA

Case Study 20



© by Argo -Anleg GmbH

Main technical features

Nominal pressure PN

20 - 500 bar

H2 Usable (10.5 Kg * 12)

126 Kg (@ 15°C)

Weight of bundle

~2950 Kg (without H2)

Temperature transmitter

-40°C to +121°C, 4-20mA, 9-36V DC

Pressure transmitter

0-700 bar, 4-20mA, 14-30V DC

Technical tight quick connections

Electrical connection

Equipped with ISO container corner fittings

Transportable via forklift/crane

Technical specifications

Description of bundle

Nominal pressure PN	500 bar
H2 usable (10.5 Kg*12)	126 Kg
Weight of bundle	~2950 Kg (without H2)

Equipment in bundle

12*MOTV per tank with TPRD	0-500 bar
1*Temperature Transmitter	-40°C to +121°C, 4-20mA, 9-36Vdc
1*Pressure transmitter + Gauge	0-700 bar, 4-20mA, 14-30Vdc
1*Manual Valve for supply line	0-1350 bar
1*Manual valve for Refill line	0-1350 bar
1*Solenoid valve for supply line	0-1350 bar
1*Check valve for supply line	0-1350 bar
1*Check valve for refill line	0-1350 bar
12*Tanks	Capacity 350L, PN-500 bar

Connections for bundle

Outlet connection	Quick connector ½"
Refill connection	Quick connector ½"
Venting connection	Quick connector 1"
Electrical connection	Harting HAN 6M 20 pins



Certificate

TPED & ADR pending

Overall dimensions

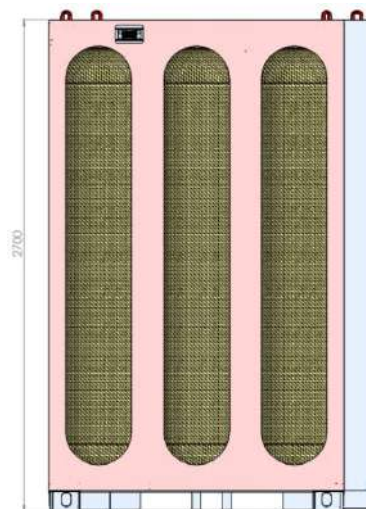
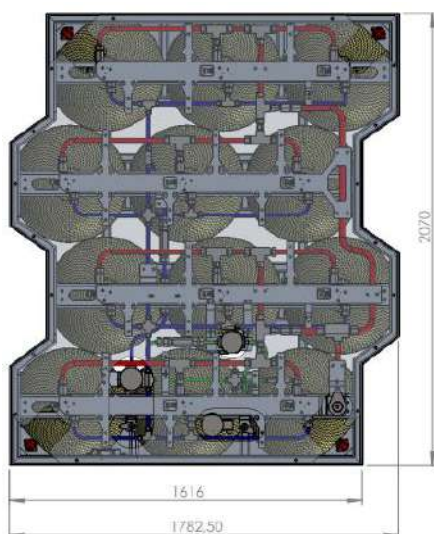

© by Argo-Anleg GmbH

Hydrogen Safety – Liquid Hydrogen (LH₂) Workshop
6th , March, 2019, Bergen,

Large Scale LH₂ Supply Chain Project & H₂ Gas Turbine Demonstration

Kawasaki Heavy Industries, Ltd.



Cryogenic Storage

Liquefied hydrogen storage tanks



Hydrogen production

Transport/Storage

Hydrogen use

Liquefied hydrogen storage tank specifications

Models	Spherical double-hull tank
Storage capacity	540 m ³
Design pressure	0.686 MPa + Vacuum
Design temperature	-253°C
Thermal insulation method	Vacuum perlite thermal insulation



Land Transport of Liquefied Hydrogen

Hydrogen production

Transport/Storage

Hydrogen use

Liquefied hydrogen transport container



Liquid hydrogen transport container specifications

Models	ISO 40 ft container
Internal volume	45.6 m ³
Unladen weight	22.3 ton
Hydrogen load capacity	2.8 ton
Thermal insulation method	Vacuum lamination thermal insulation
Accessories	Pressure evaporator



Dealfeng Rotor Sail Delivery Time Table

Date - Type	24m×4m+Fixed foundation	24m×4m+Folding foundation	30m×5m+Fixed foundation	30m×5m+Folding foundation
2022.07	√	√		
2023.05	√	√	√	√
Delivery after order	4 months	4 months	4 months	4 months
Production target	20units/ year (Dec.2023)			

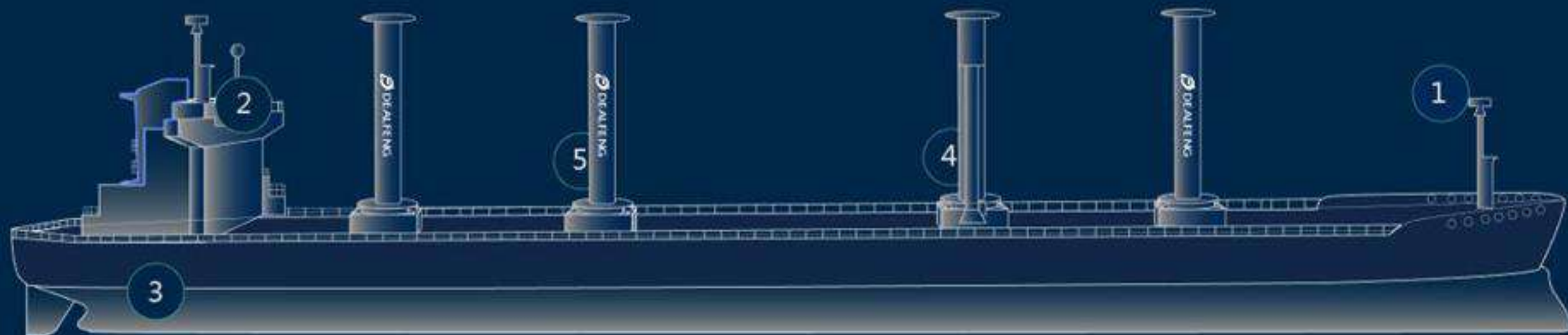

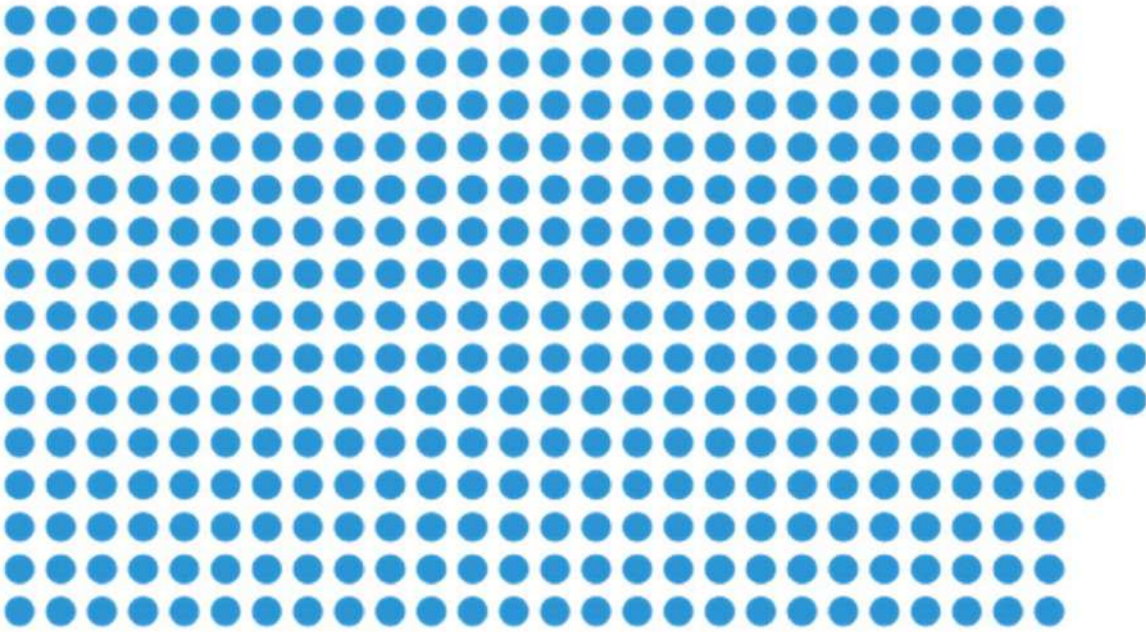

The Silverstream [®] System – Air Lubrication
The smart, verifiable, high impact efficiency technology

www.silverstream-tech.com

Silverstream® System Reference List

65 x Boxship

15-24k teu



MAERSK



25 x Gas

LNGC 168-175k cum
CO2 7.5k cum



21 x Ro-Ro & PCTC

5-7.5k LM
8.8K tcu

GRIMALDI GROUP

1 x VLOC

325k dwt



VALE

2 x Combo Carrier

85k dwt



Torvald
Klaveness

18 x Cruise

115-185k GT

NORWEGIAN
CRUISE LINE

Carnival

SILVERSTREAM
TECHNOLOGIES

Simple installation – Suitable for retrofit & newbuild

Installation during normal dry-dock window

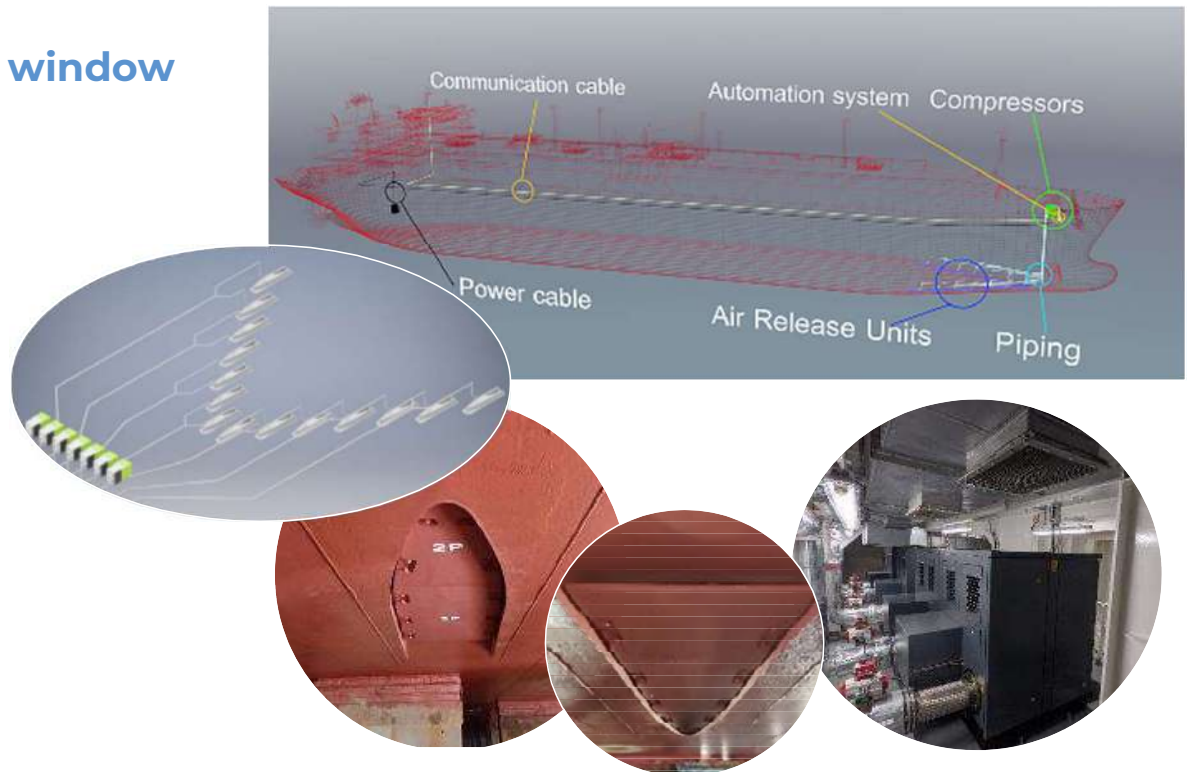
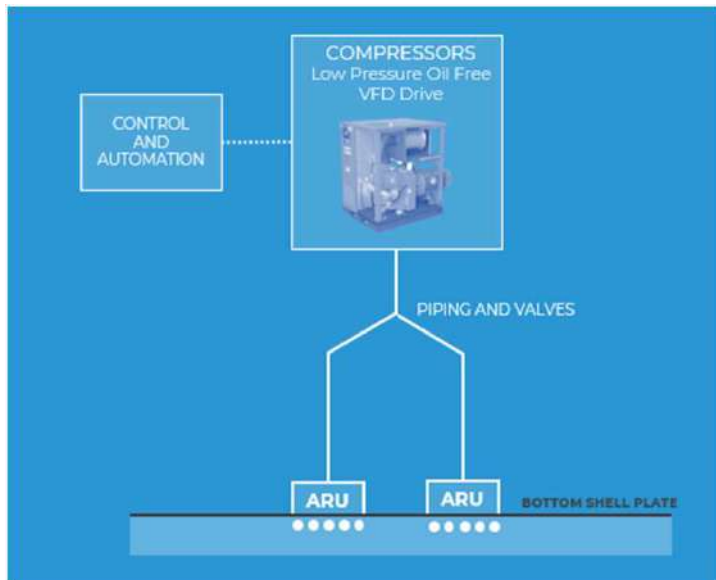

Verified performance

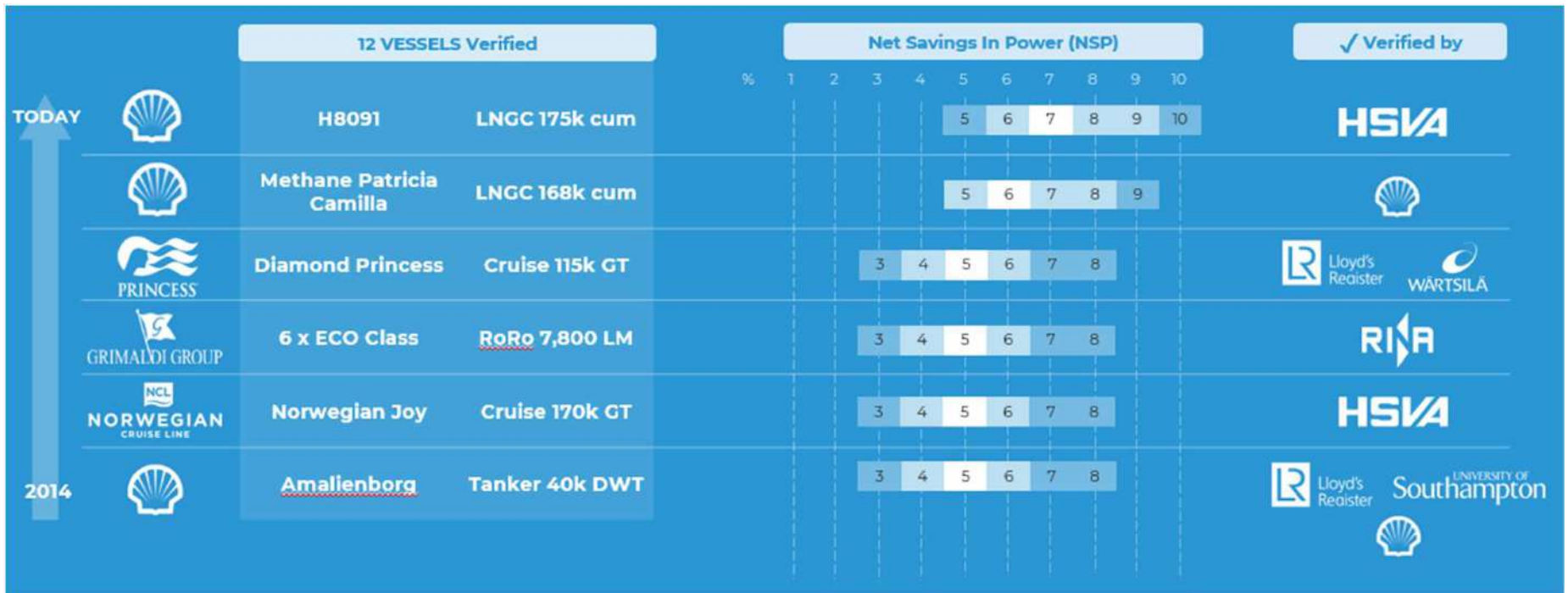

SILVERSTREAM
TECHNOLOGIES



huyvane

WE MASTER HYDRODYNAMICS



Our patented Hull Vane® is a proven energy-saving solution for low to medium-speed displacement vessels. Combining Computational Fluid Dynamics (CFD) and our in-depth knowledge of hydrodynamics, we can customise and optimise the design of each Hull Vane® to achieve the highest level of performance. The Hull Vanes are available in three variants, the T- and U-series and Specials.

**THE SIZE OF HULL VANE® WHICH IS MOST SUITABLE FOR YOU
DEPENDS ON THE VESSEL'S LOA. SEE BELOW:**

T-SERIES	U-SERIES	LOA (metres)	
		FROM	UP TO
T-400	U-400	10	22
T-750	U-750	22	36
T-1000	U-1000	36	49
T-1250	U-1250	49	62
T-1500	U-1500	62	75
T-1750	U-1750	75	87
T-2000	U-2000	87	100
T-2250	U-2250	100	112
T-2500	U-2500	112	>

effectiveness

The Hull Vane® is particularly effective when fitted to displacement, semi-displacement and fast-displacement vessels.

Suitable candidates for a Hull Vane® include coastguard/naval vessels, passenger ships, ro-ro ships, expedition cruise ships, fast supply vessels and motor yachts.

For these types of vessels, energy savings of between 5% and 20% are typical, and in some cases even 25% savings are attainable.

APPLICATION RANGE

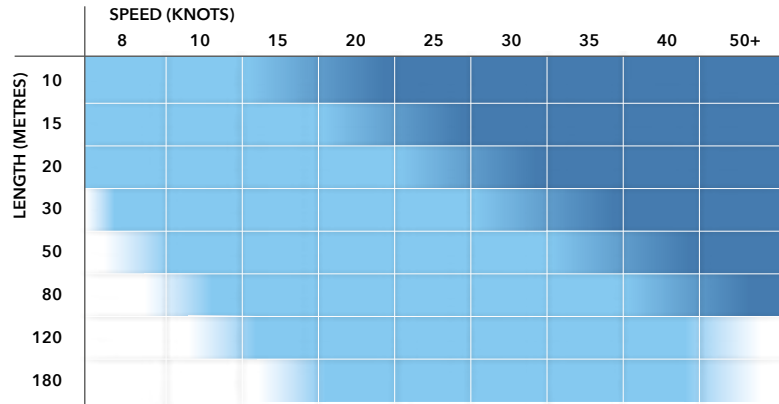

HULL VANE®

FOIL ASSIST

proven results

YACHTS



20%
LESS RPM
@CRUISING
SPEED

17.5m Sturiër 565 OC - **Hemera**



7 dB(A)
LESS NOISE ON
AFT DECK

18.5m Yerseke Offshore 62 - **Colinda**



20%
LESS FUEL
CONSUMPTION

20m Vripack Trawler - **Amoc**



18%
MORE
RANGE

36m Dynamiq GTT 115 - **Jaaber**



25%
SMALLER
ENGINES

42m Heesen - **Ares**



14%
MORE
RANGE

34m Van der Valk Explorer - **Lady Lene**



DETERMINE WHICH IS
THE RIGHT SOLUTION
FOR YOUR VESSEL BY
USING OUR
CONFIGURATOR

COMMERCIAL



15%
LESS FUEL
CONSUMPTION

55m FSIV - **Karina**



15%
LESS CO₂
EMISSIONS

30m Ferry - **Valais**



14%
LESS
PITCHING

57m Guard Vessel - **Linde-G**

NAVAL & PATROL



>10%
LESS FUEL
CONSUMPTION

108m OPV - **HNLMS Groningen**



57,000 l/year
LESS FUEL
CONSUMPTION

25m Patrol Vessel - **RPA8**



20%
LESS CO₂
EMISSIONS

52m OPV - **Thémis**

Solarhatches for inland vessels

Existing projects:

MS Addio, MS Kenyro, MS Mededinger, MS Concordia, MS Sira M, MS El Teide, MS Tampico, MS Oleander.

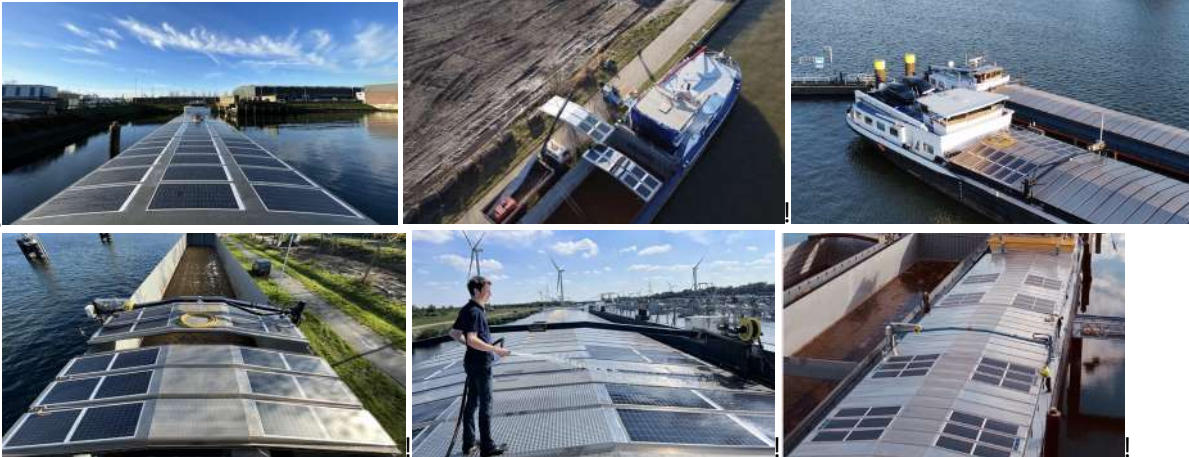

Upoming projects:

HGK, MS Fundament, MS Victus, MS Viator, MS Variant, MS Amarige, MS Dependant, MS Wilhelmina Arina.!



Current results - technology implemented directly/now:

Large vessel (135m)

- Yearly usage (propulsion + hotelload)¹: 1.093.941 kWh
- Yearly solar energy generation with complete solarhatch set²: 108.000 kWh (134 kWp installed)

Percentage of energy/fuels savings³:

12%

Yearly fuel savings³:

32.909 L

Yearly carbon emissions savings³:

107 tonnes

Average size vessel (110m)

Percentage of energy/fuels savings³:

12%

Yearly fuel savings³:

24.966 liter

Yearly carbon emissions savings³:

81,5 tonnes

Mid term future results - when implemented in 2035

Results of an average vessel (110m):

Percentage of energy/fuels savings⁴:

20%

Yearly fuel savings⁴:

33.967 L

Yearly carbon emissions savings:

111 tonnes

Potential of the European market (3000 vessels with suitable hatch covers):

Current technology implementation	Future technology implementation (2035)
75 million liter fuel savings per year	102 million liter fuel savings per year
244 kilotonnes CO2 reduction per year	332 kilotonnes CO2 reduction per year

References and calculations:

1. based on existing data of the MS Jolina and MS Kenyro
2. Energy yield based on average of real measurements on inland vessels in kWh/kWp, including losses due to shadow, disconnected hatch covers, etc.
3. Fuel and CO2 savings:

135m vessel			
Energy yield	108.000 kwh		
	Hotelload	Propulsion	
consumption	109.394	984.546	kWh
SFC	270	210	g/kWh
fuel usage	29.536	206.755	kg
density	0,827	0,827	kg/L
fuel usage	35.715	250.006	L
solar energy	75.600	32.400	kWh
fuel savings	24.682	8.227	L
total fuel savings	32.909		L
total fuel usage	285.721		L
percentage savings	12%		
CO2 emissions fuel	3,262		kg/L
CO2 reduction	107350		kg

110 vessel			
Energy yield	81.931 kwh		
	Hotelload	Propulsion	
consumption	82.989	746.897	kWh
SFC	270	210	g/kWh
fuel usage	22.407	156.848	kg
density	0,827	0,827	kg/L
fuel usage	27.094	189.659	L
solar energy	57.351	24.579	kWh
fuel savings	18.724	6.241	L
total fuel saving	24.966		L
total fuel usage	216.754		L
percentage savi	12%		
CO2 emissions	3,262		kg/L
CO2 reduction	81438		kg

Note: Solar energy is first fed into the hotelload grid. Surpluses support propulsion. This results in 70% of yearly solar energy yield feeding the hotelload and 30% feeding propulsion.

4. Situation in 2035 compared to current situation:

- Efficiency gain of solar panels from 21% to 30% (perovskite tandem cell)

<https://www.dnv.com/to2030/technology/solar-pv-powering-through-to-2030.html>

- Efficiency gain of ships fuel usage of 20% (15-25%) by improved ship design

https://www.cesni.eu/wp-content/uploads/2021/03/cesnipt_energyindex_en.pdf

110 vessel future			
Energy yield	117.044 kwh		
	Hotelload	Propulsion	
consumption	66.391	597.518	kWh
SFC	270	210	g/kWh
fuel usage	17.926	125.479	kg
density	0,827	0,827	kg/L
fuel usage	21.675	151.728	L
solar energy	58.522	58.522	kWh
fuel savings	19.106	14.860	L
total fuel savings	33.967		L
total fuel usage	173.403		L
percentage savir	20%		
CO2 emissions fi	3,262		kg/L
CO2 reduction	110800		kg

Incat Hull 096

The world's largest all-electric ferry is under construction in Australia by Incat Tasmania. The vessel will feature the largest energy storage system (ESS) system to be installed on a vessel of any battery propulsion type. At 40 MWh, the battery system is an almost four-fold increase in ESS size compared to the next largest. Corvus Energy will provide their Dolphin NextGen ESS.

The vessel will be delivered to Uruguayan ferry operator Buquebús and will operate between Montevideo (Uruguay) and Buenos Aires (Argentina) in 2025. The new ship, which is known as Hull 096, will have capacity for 2,100 passengers and crew and up to 225 cars.

The ferry is a catamaran with an ultra light design built with aluminium. Wärtsilä will supply the energy management system, the power conversion system, DC shore charging system, the DC hub, 8 electric motors, 8 axial flow WXJ1100 waterjets, and the ProTouch propulsion control system.

Service Operations Vessel 7017 E



Features:

- » Zero-emission
- » Damen's DPX-DRIVE™

GENERAL

The vessel serves to provide hotel functions and stepless access onto Offshore Wind Farm structures for technicians, tools and parts by access system, optional crane and daughter craft. The vessel is able to run fully on batteries, allowing for zero-emission operations. Offshore charge systems are an integral part of the total solution. .

Classification	✘ 1A Windfarm Service Vessel, Strengthened(DK), E0, Battery(Power), DYNPOS(AUTR), COMF(V-2, C-2), ER(SCR), Clean (Tier III), BIS, LCS
----------------	---

DIMENSIONS

Length overall	70.1	m
Beam moulded	17.0	m
Service draught	4.5	m
Gross tonnage	4300	GT

CAPACITIES

Fuel oil	Approx. 260	m ³
Fr. water, potable	Approx. 90	m ³
Cargo weather deck area	Approx. 300	m ² (6 x 20ft cont.)
Covered warehouse areas	Approx. 420	m ² main deck

PERFORMANCES

Speed @ summer draught	12.0 / 10.0	kn max / eco
Endurance	28	days

PROPULSION SYSTEM

Propulsion	4x 900 kW azimuth thrusters in double-ended arrangement for optimal maneuvering
------------	---

ZERO-EMISSION SOLUTIONS

The vessel is offered with 2 options of battery systems:

- » 10 MWhr, suitable for approx. 75% full-electric operations
- » 15 MWhr, suitable for approx. 98% full-electric operations

Batteries are of Lithium Iron Phosphate (LFP) type, for high inherent safety and reduced ecological footprint.

For backup, emergency and mobilization purposes 2x 1200 eKW HVO / diesel generators are provided which allow the vessel to continue all operations, even with depleted batteries.

The vessel is charged via a receptacle on the stern by a 4MW/11kV connector. Transfer of a charge cable is by means of a manipulator, attached to the tip of the motion compensated gangway. Connecting / disconnecting is without manual intervention, fully controlled from the gangway's operator position.

Offshore charge stations, fully compatible with the vessel, are to be installed on offshore wind turbines and / or offshore substations and can be delivered via Damen's specialized partners.

MISSION EQUIPMENT

Motion compensated gangway	3D MCG 25m length, mounted on a tower with integrated elevator. The gangway is Adjustable to a working height of 14m to 25m above sea level.
Helicopter winch area	On foreship, stepless access to warehouse and hospital.
Boat landing facilities	Steel boat landing at stern with height-adjustable platform and walkway, adjustable between 1m and 4m above sea level, providing direct access into warehouse without the need for fall arrestors.
Refueling stations	Boat landing is provided with refueling station for fuel and urea. MCG is provided with utility lines to supply fresh water, fuel and electric power to offshore structures

ACCOMMODATION

Cabins	Max. 60 PoB. 60 x single cabins. All fitted with high-speed Wifi and access to Video on Demand
Comfort	The vessel provides hotel-style accommodation with high comfort levels due to a.o. low vessel motions, low noise levels, high-standard climate control, state-of-the art internet and entertainment systems and well-designed way-finding systems.
Office Leisure	Large office spaces, multiple (flexible) conference rooms Feel at home, away from home. Attractive, inviting lunch café / restaurant, large gymnasium, game rooms, cinema

NAUTICAL AND COMMUNICATION EQUIPMENT

DP-system	DP-2 with target-less Laser PRU and 2x DGPS PRU. High-speed auto track capability
Motion prediction	Wave radar with motion prediction capability, for improved safety and operability during offshore transfer operations
Communication	VSAT, 5G, TVRO, prepared for LEO

OPTIONS

Charge stations	Offshore charge stations, fully compatible with the vessel, can be delivered as an option via specialized partners.
Helicopter deck	The winch area can be fitted as a landing area with a D-value of 17m
Daughter craft	Up to 1x 15m daughter craft and LARS, choice of leading OEM.
Motion compensated offshore crane	Various crane options are possible. E.g.: 3D MCG offshore crane. SWL 2 ton MCG; SWL 10 ton in harbor

Service Operations Vessel 7017 E

Features Damen's DPX-DRIVE

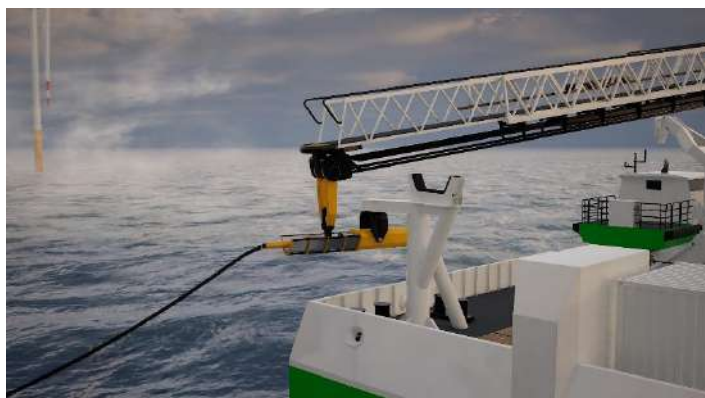

DAMEN

Damen.com

©This product sheet is designed to inform about Damen and its product(s). All data presented is preliminary and subject to changes. No rights can be derived from this information with regard to dimensions, characteristics or performances of any of the products shown. Damen is not liable for the consequence of taking on the information from the product sheet. The entire contents of this product sheet (text, drawings, photos, etc.) is copyrighted and may not be reproduced or distributed without the specific written permission of Damen.

CASE STUDY

PwrSwäp - Singapore

- PwrSwäp in Singapore for deployment at Jurong Port. Q1 2024
- PwrSwäp 1 -- a 3MW charging station located at Jurong Port, with ePod swapping cartridges supported on two transfer platform vehicles (TPV) and charging for up to 8 ePods on each TPV.
- On the site there are four cranes with capacity 10-20 ton, each loading and unloading a vessel within 30 minutes currently.
- The Yinson Flyer and Hydromover will be operating from this base, acting as both a crew transfer vehicle (Flyer) that can speed at 30 knots on next generation hydrofoils, and a Short Freight Vehicle (Mover) that will carry up to 10 ton of cargo at 12 knots. Both vehicles will operate 12 hours a day.

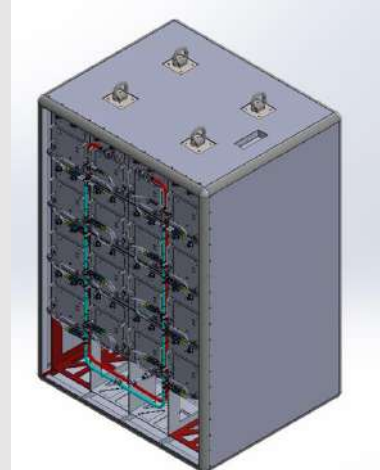

LAUNCHED NOV 2023

PwrSwäp - Singapore

Vessel Specs:

Length overall: 18.50 metre

Beam moulded: 8.00 metre

Clear Deck Area: 60.0 m²

Design Draught: 1.45 metre

Operating Speed: 8 to 10 knot

Sprint Speed: 12 knot

Complement: up to 4 Crew + 8 passenger

Max. Cargo Load: 20 mt

Gross Tonnage: 80 GT

No. of Battery: 6x ePods = 420 kWh

Electric propulsion power: 235kW x2

Mode of Charging: Battery Swap + Plug in Charging (CCS2)

Launched November 2023

HYDROMOVER



Class Notation

RINA C ⚡ Hull • MACH, Workboat, NAV30, Battery Powered Ship



LH2 SHIPPING

Ship design and operations

Detailed voyage analysis are conducted to:

- Define energy requirements for all voyage elements
- Define fuel costs and other OPEX
- Assess energy reduction equipment (sails, etc.)
- Optimise the onboard LH₂ system
- Develop bunkering schedules as part of voyage
- Plan port stays with shore power and/or FC operations

Resulting in cargo ship designs, such as:

Length over all:	95m
Molded depth:	8m
Beam:	16m
Fully loaded draught:	6m
Deadweight capacity:	5000t
LH ₂ storage capacity	15 tons
FC system	2MW

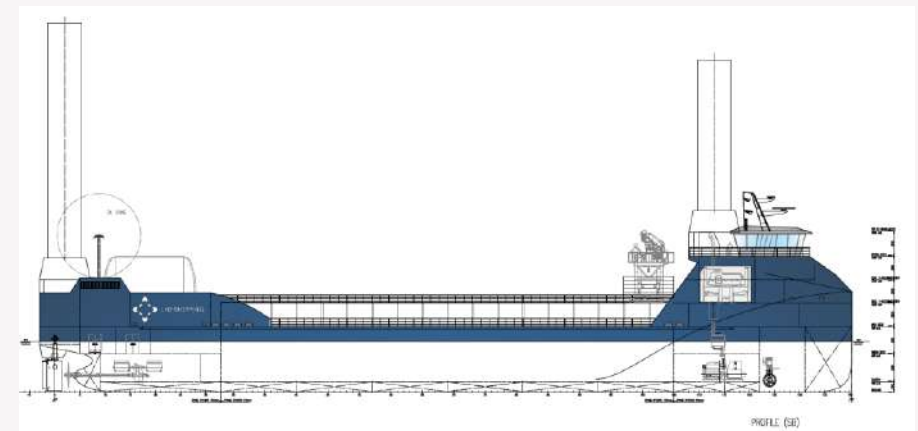

Pictures: LMG Marin

H₂ Barge 1 and the dawn of inland hydrogen propulsion



On 25 May this year, Future Proof Shipping launched the first hydrogen powered zero emissions inland shipping container vessel – the H₂ Barge 1. Since then, the vessel, previously known as FPS Maas, has been operating between the Port of Rotterdam and the BCTN terminal in Meerhout, Belgium.

The vessel is on charter to BCTN who operate it on behalf of Nike EMEA, based in nearby Laakdal. In a boost for maritime sustainability, H₂ Barge 1 is expected to reduce greenhouse gas emissions by in the region of 2000 tonnes of CO₂ equivalent per year.

The vessel's Captain, Dragoş Lupu graduated from naval high school in Romania back in 1988 and has, since then, worked

exclusively in the inland shipping sector. Having sailed aboard the ship for over a month now, Captain Lupu gives his verdict on the performance so far.

"My first impressions have been surprisingly good. I say surprisingly because I anticipated that it would take me some time to get used to this new ship but, actually, the operation is the same as on a conventional vessel. It's been very easy

to get to grips with it." One of the characteristics that Captain Lupu expected to be a challenge was the vessel's reduced propulsion.

"Previously the vessel sailed with 1100hp, while now it has 1088hp. However, this is certainly sufficient for the vessel's needs. I think it's fair to say, the engineers – who have committed themselves body and soul to the devel-

opment of this vessel – have done an excellent job."

Confidence in future

Captain Lupu says the vessel has got off to a good start and that the crew take pride in being associated with its sustainable profile. "The vessel is performing very well, and we are all proud to be a part of this new chapter in maritime history. We take great satisfaction from the fact that our work is not creating emissions. With rising demand for maritime sustainability, we are able to look with confidence towards the future, with all its hopes for a cleaner, healthier environment."

Working environment

With emissions so significantly reduced, the benefits for the environment are clear. However, as Captain Lupu points out, the H₂ Barge 1 also offers a number of benefits for those on board.

"The advantages of a hydrogen powered vessel are significant, and they are also plain to see. For one thing, the ship is practically silent – which must surely be of benefit to life on and under the water as well as those aboard. Also, there is no smell of exhaust gas in the air, and, with no exhaust gas, the ship stays very clean. It's a very pleasant environment to work in."

A second home

"That's important to us; we spend a lot of time on board. The ship is a second home for us. As crew we're co-habiting, it's like being in a family." For Captain Lupu, this comparison is particularly relevant; his son Alex sailing aboard the H₂ Barge 1.

"This all started when Alex was in high school. He had vacation so I brought him onboard with me so he could see where I worked. After that, even though he has a degree in another field, he chose a career in navigation."

Next generation

Alex is just one of the new generation of inland shippers that Future Proof Shipping is looking to work with as it develops its fleet of hydrogen powered vessels for the future, as Director of Operation Fokke van der Veen explains, "As we seek to further maritime sustainability, we are looking not only to build a sustainable fleet, but a sustainable team. This includes a crew with a passion for the environment and its stewardship and who would be proud to be part of the zero emissions future we are working towards."

Captain Dragoş Lupu and his son Alex sail together on the H₂ Barge 1, the first hydrogen powered inland shipping vessel



By Ben Littler

MF Hydra: Operations & life onboard

Lessons learnt:

- Decoupling: be careful not to submit coupler to mechanical forces → currently modifying crane to be free-hanging
- Moisture in sealings can cause issues in heavy rain which can freeze in cold weather, this is more able to influence operations than LNG
- Standards for truck coupling: Industry should look at standards for truck coupling: 4-5 types have been seen and there was back-and-forth at the beginning. Truck bunkering must be designed to allow purging. EU vs US manufacturing: mm vs inch measurements are not identical and LH2 equipment is more sensitive to such errors than LNG & diesel equipment

Liquid hydrogen is much less likely to self-ignite than compressed gaseous hydrogen due to the cryogenic low temperature. There is a lower risk of leak and any leakage is at low pressure and will be closed off and die out.

Crew testimony:

- The vessel is operating safely and smoothly
- Crew are comfortable with operations and maintenance
- Many visits to the ship - the crew are demystifying LH2
- No issues, they feel safe - very relaxed, working well

Boil off:

- No boil-off from fuel cells in operation. If fuel cells are not used, over time the H2 leaks out the system but fuel cells are constantly in operation so this has not occurred
- No boil-off from bunkering
- End of bunkering decompression causes ~15kg boil-off. For the next project, this will be collected in a container and reused.

Maintenance & down time:

- Estimates 99.8% working time
- Planned maintenance programs carried out without issue
- Fuel cells run every day - start in morning at 50% then run all day 16 hours, then switch off at night
- 2 fuel cells mean redundancy and maintenance while 2nd FC runs
- 1 week planned dry dock for fuel cells upgrade

Dealfeng Rotor Sails

At present, Dealfeng New Energy Technology has completed the installation of its 4m (diameter) x 16m (height) rotor sail on a new-build 5,000-ton class product oil tanker in November 2023. The vessel, name of Hai Jun 56, length O.A 95.90m, breadth mld. 15.80m, depth mld. 7.00m, design draught 5.95m, design deadweight 5474.92 m³, service speed 11.8 knot, Class B ice area strengthened, is scheduled for delivery in early 2024 and is expected to deliver a reduction of around 8% in terms of fuel and greenhouse gas emissions.

Additionally, following the signing of a retrofitting contract with Offshore Oil Engineering Co., Ltd. (COOEC), Dealfeng will finish the installation of two sets of 4m x 18m rotor sails on a 25,000 DWT deck carrier called by HAI YANG SHI YOU 226 (IMO is 9577707) classed in China Classification Society (CCS), which will be delivered in December 2023 and is expected to achieve bunker consumption and emissions reduction of around 10%. Once successfully delivered in December 2023, it will become China’s first commercial retrofitting project of wind-rotor assisted propulsion system from local rotor manufacturer.

Dealfeng’s rotor sail is made of lightweight and strong composite material, and it features a fully automatic control system and its technology readiness level (TRL) has reached level 9. The sail generates forward thrust as the wind creates pressure differences around the rotating rotor while a vessel is sailing. When using this technology, a vessel is expected to achieve a reduction of fuel consumption and carbon emission of around 5-25% or even more when wind conditions are favourable.

As the first company in the world to obtain the certificate of Type Approval of marine wind-rotor assisted propulsion system from China Classification Society (CCS), Dealfeng New Energy has obtained the certificate of Approval in Principle (AiP) of rotor sail system from LR, NK and CCS as well as the certificate of Works Approval from CCS. Dealfeng can provide customer with comprehensive services of design, manufacturing, installation and debugging as well as the general contracting services for rotor sail on new-build and/or existing ship retrofitting projects.



5000-ton class vessel JUN BAI 56

[Econowind](#) turbo sails allow ship owners to achieve fuel savings of up to 30 per cent, promoting sustainability within the shipping sector.

The eConowind 16-metre aluminium unit can be retrofitted or incorporated on newbuilds and can be ordered as a standard 20-foot ISO containerised unit. They generate up to 400 kW of power and are fully automatic, adjust for wind speed and direction, and can be started from the ship's bridge.

VentoFoil® units solid on a vessel is mainly the possibility to use bigger foils. Bigger foils are able to produce much greater forward force and thereby fuel savings. The VentoFoil units are able to fold and rotate around its own axis, thereby it can be always made possible to access the ship's cargo hold.

The Ventofoil Flatrack unit is based on ISO-fix corners and can quickly be placed and removed. Each flatrack can be adjusted to the size of the vessel.

The largest order to date is for [12 Ventofoil wind drives for three tankers](#) that the Danish shipping company Terntank is building in China. Other orders include:

- ONE (2 containers)
- Chemship (1 ship, 4 wings)
- Onego (2 wings)
- Kroezen (2 ships, 4 wings)
- De Bock (1 ship 2 wings)
- NYK (1 ship, 2 wings)

In light of the full order book, Econowind is moving in December 2023 into a new factory 3 times the current size to scale up production. They recently received [investment from NOM, Horizon Flevoland](#) and 3 private investors. By 2027, they aim to produce at least one unit daily, with operations in Zeewolde, Warten, and an additional global location.

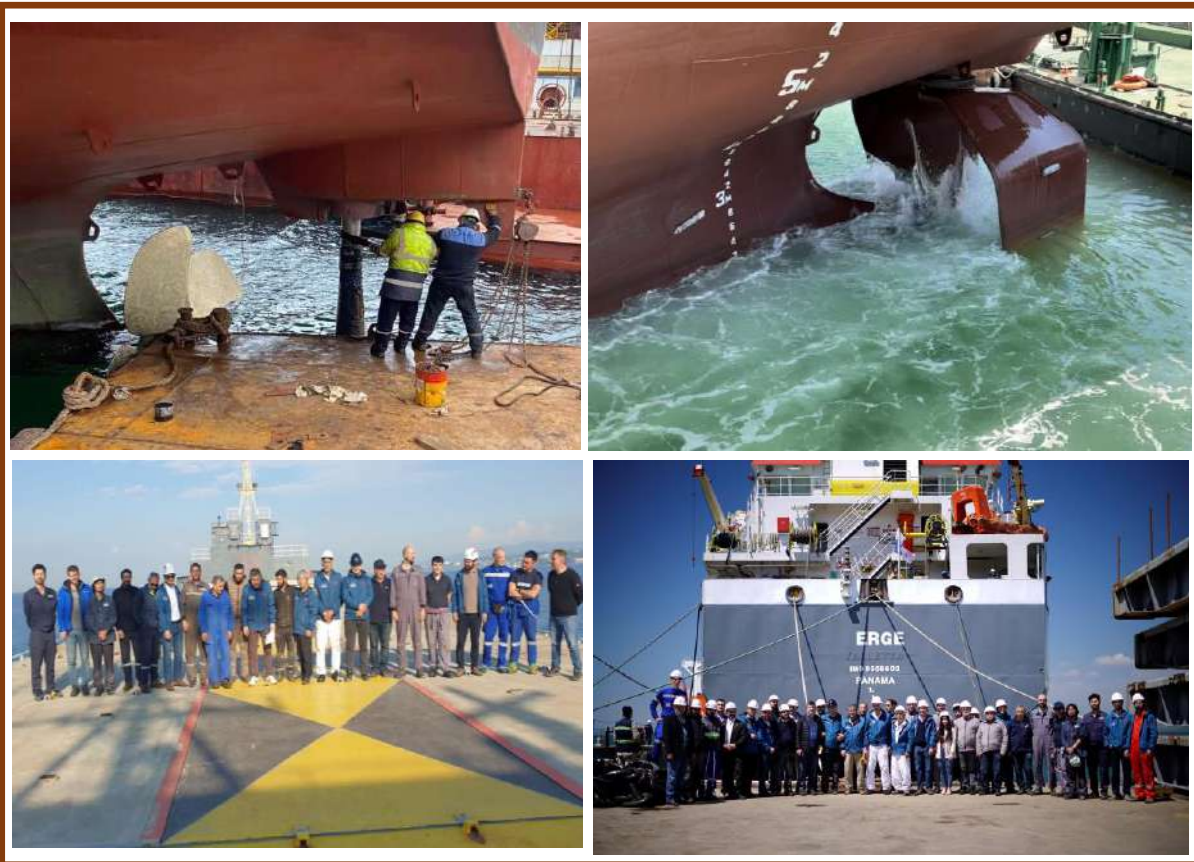

“An Effective and Quieter Energy Saving for Ships”

H2020 Project GATERS

Presented By

***The GATERS Project Coordination Team,
(Prof Mehmet Atlar & Dr Cagatay Koksal)***

***The University of Strathclyde
Dept of Naval Architecture, Ocean & Marine Engineering
Glasgow, UK***



GATE RUDDER SYSTEM (GRS)



CONV' RUDDER SYSTEM (CRS)

	SHIGENOBU (1 st appl, 2017)	KOHSIN MARU (2 nd appl, 2020)	SHINMON MARU (3 rd appl, 2020)	NOGAMI (4 th appl, 2022)	OSHIMA MARU (5 th appl, 2023)
Ship type	Container (400 TEU)	G/Cargo (509 GT)	G/Cargo (499 GT)	Container (550 TEU)	Training ship (370 GT)
Lpp	101.9	69	72	136.25	47.2
B	17.8	12	12	21	10.6
T	5.24	4.11	4.13	6	3.4
C _B	0.67				
Design Vs	14.5	13	13	16.5	13
Fn (Lpp)	0.2436	0.267	0.267	0.23	0.31
L/B	5.72	5.75	5.75	6.5	4.45
Stern shape	Stern bulb	Stern bulb	V shape	Stern bulb	Stern bulb

2 more ships
are in order in
Japan
for
2023-24:

- 20K DWT Bulker (2023)
- Ro-Ro vessel (2024)



GRS - Energy saving capability

SAKURA		
Length overall	LOA (m)	111.40
Length between perpendiculars	LBP (m)	106.40
Breadth	B (m)	17.80
Design Draught (midship)	T (m)	5.24
Displacement	Δ (ton)	4794
Service Speed	V _s (knots)	15.5
Rudder		CRS



SHIGENOBU		
Length overall	LOA (m)	111.40
Length between perpendiculars	LBP (m)	106.40
Breadth	B (m)	17.80
Design Draught (midship)	T (m)	5.24
Displacement	Δ (ton)	4794
Service Speed	V _s (knots)	15.5
Rudder		GRS

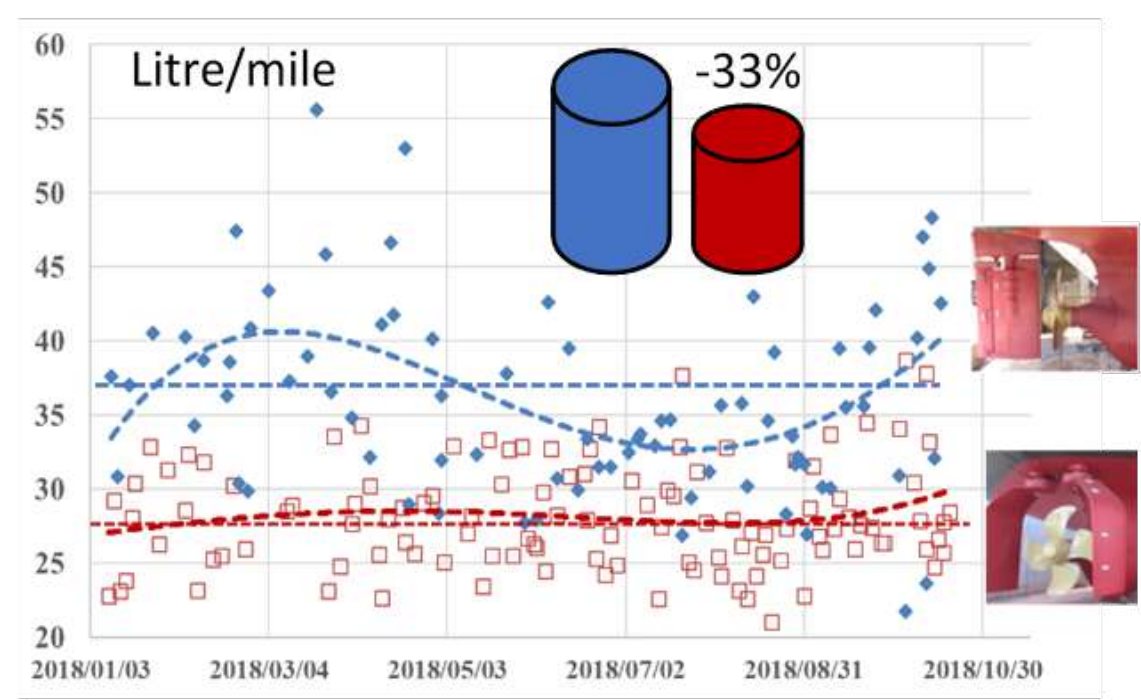
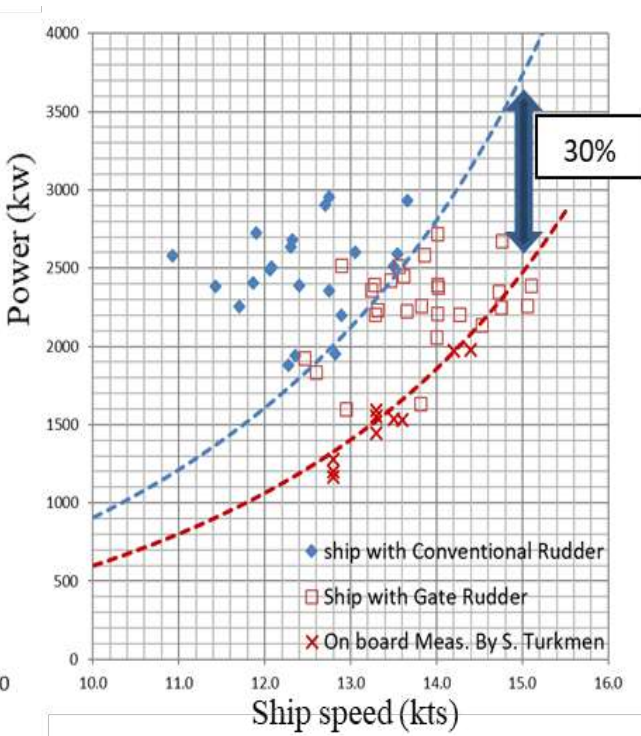
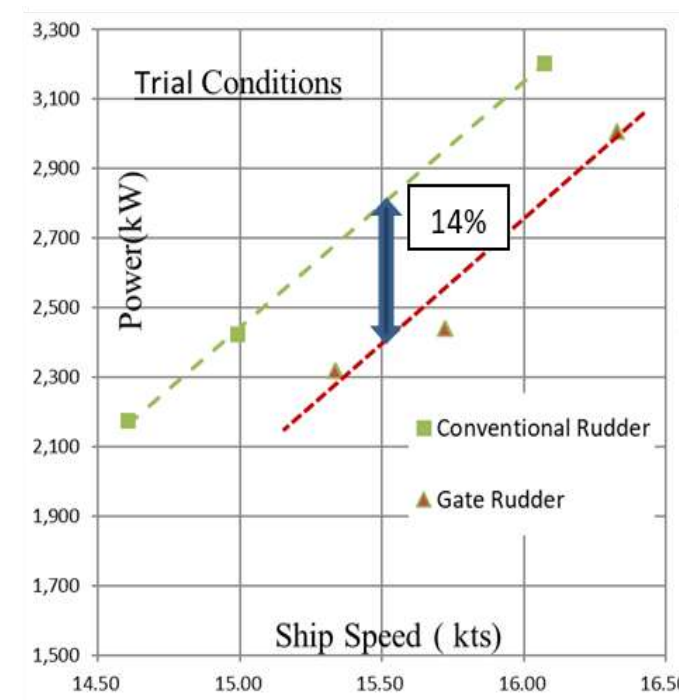

Trials (calm water) and in-service (including rough weather) powering performance comparisons of two sister ships: one **Shigenobu** with Gate rudder system **vs. Sakura** with Conventional flap-rudder system

In-service fuel consumption comparisons of two sister ships, **Shigenobu** with GRS (red) vs. **Sakura** with CRS (blue)

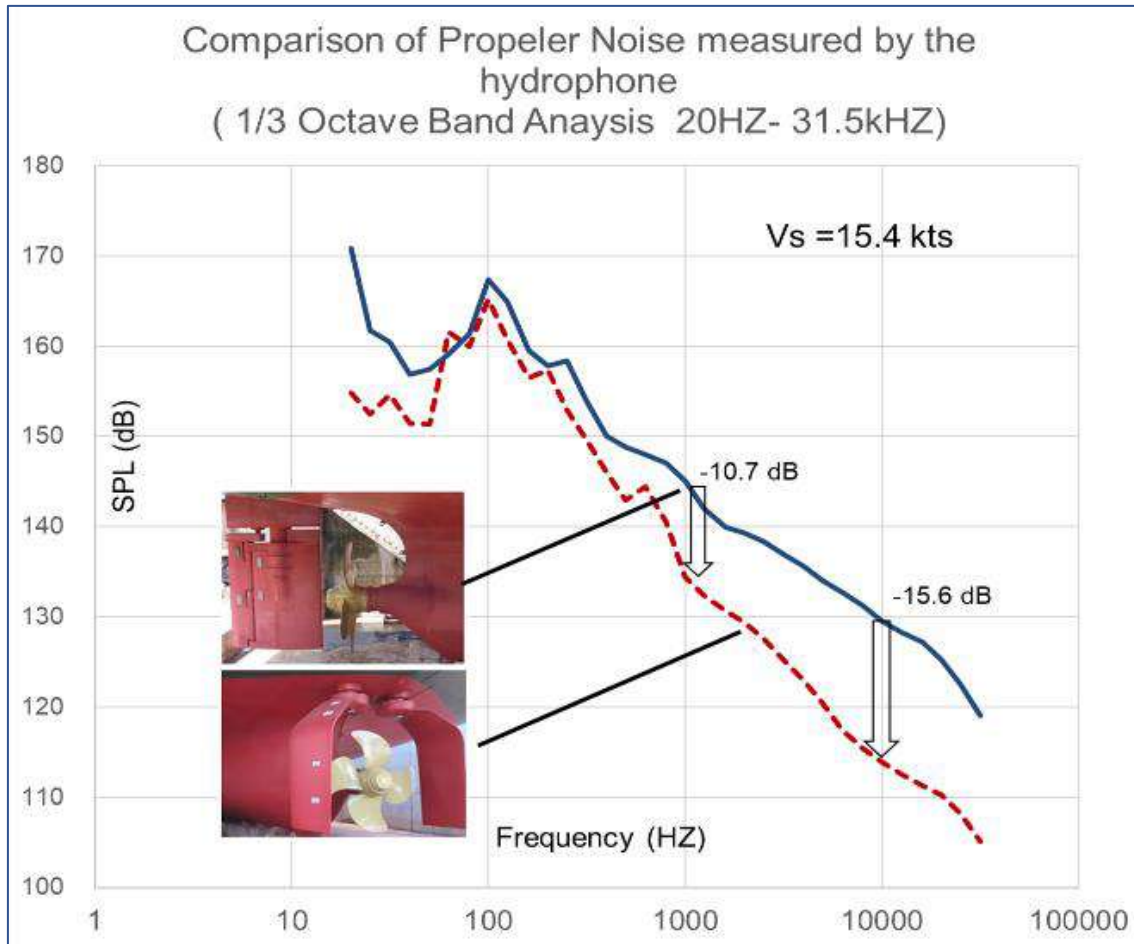

Comparative Underwater Radiated Noise (URN) levels of Sakura (CRS) and Shigenobu (GRS) from trials

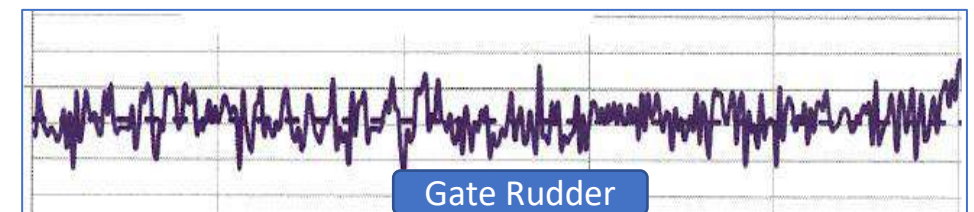
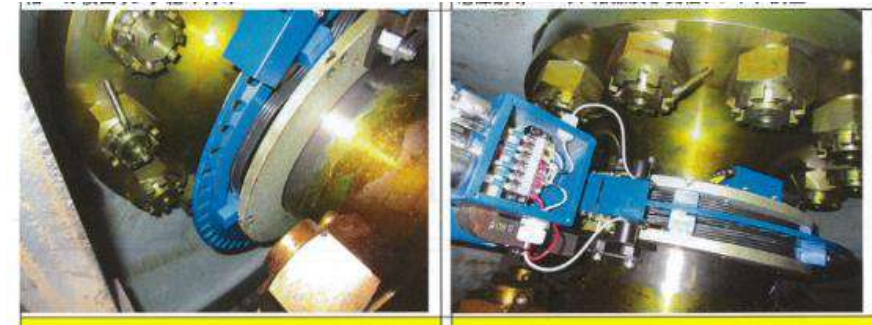

Comparative shaft torque records for GRS and CRS using the same torquemeter

Concluding remarks

- The GRS is a **novel energy saving device** (ESD) for ships, presenting **attractive savings**, which is more than any other ESDs available can provide **as a sole device**.
- Inherent design features of the GRS help **to reduce URN** of ships **without compromising** the saving energy.
- The **application** of GRS on a “**new-built**” coastal container vessel in trial conditions demonstrated that the URN reduction can be as high as 15dB while the energy saving is around 15% compared to her sister ship.
- The “**retrofit**” **application** of GRS on an “existing” coastal G/Cargo vessel in trial conditions can also display up to the same level of URN mitigation while presenting a massive 35% fuel saving
- GATERS project had successfully achieved its most important objective, i.e., design, build and demonstrate **the first retrofit application** of the GRS on a commercial coastal vessel that was also the first application of the GRS **outside Japan**.
- Since her retrofit with GRS, MV ERGE has been **sailing efficiently in the past 5 months** while her powering/fuel performance has been monitored in-service to assess her performance further

